

VALVOLA RIDUTTRICE DI PRESSIONE DIRETTA DIRECT ACTING PRESSURE REDUCING VALVE

TIPO / TYPE
VRP

SCHEMA IDRAULICO
HYDRAULIC DIAGRAM

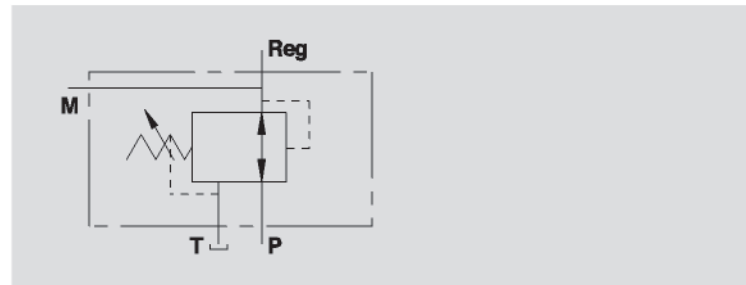
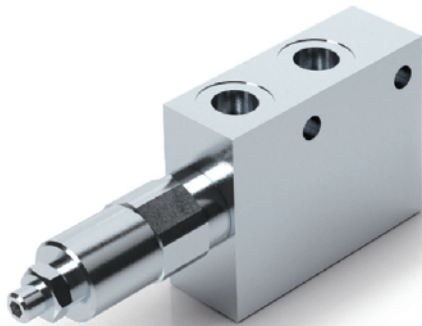

IMPIEGO:

Valvola che permette di mantenere costante la pressione a valle indipendentemente dalla pressione a monte.

USE AND OPERATION:

This valve maintains a constant downstream pressure irrespective of the upstream pressure.

MATERIALI E CARATTERISTICHE:

Corpo: acciaio zincato.
Componenti interni: acciaio temprato termicamente e rettificato.
Guarnizioni: BUNA N standard.
Trafilamento: 70 cc/min (con 350 Bar alla bocca P).

MATERIALS AND FEATURES:

Body: zinc-plated steel.
Internal parts: hardened and ground steel.
Seals: BUNA N standard.
Leakage: 70 cc/min (350 Bar to port P).

MONTAGGIO:

Collegare P al circuito principale, Reg. al circuito dove si desidera ridurre la pressione e T allo scarico.

CONNECTIONS:

Connect P to the main circuit, Reg. to the circuit where you want the reduced pressure and T to the tank.

**PRESSIONE/PORTATA
PRESSURE /FLOW**

Temperatura olio: 50 °C - Viscosità olio: 30 cSt
Oil temperature: 50 ° C - Oil viscosity: 30 cSt

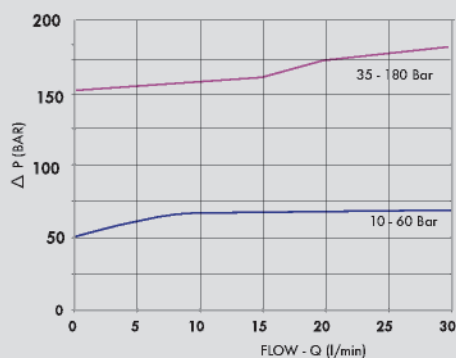



CODICE CODE	SIGLA TYPE	PORTATA MAX MAX FLOW Lt. / min	PRESSIONE MAX MAX PRESSURE Bar
----------------	---------------	--------------------------------------	--------------------------------------

V0704/000*	VRP 3/8"	30	350
V0706/000*	VRP 1/2"	30	350

*000 = specificare valore della molla desiderata. Vedi tabella sotto.
 *000 = please specify the desired setting range. See the table below.

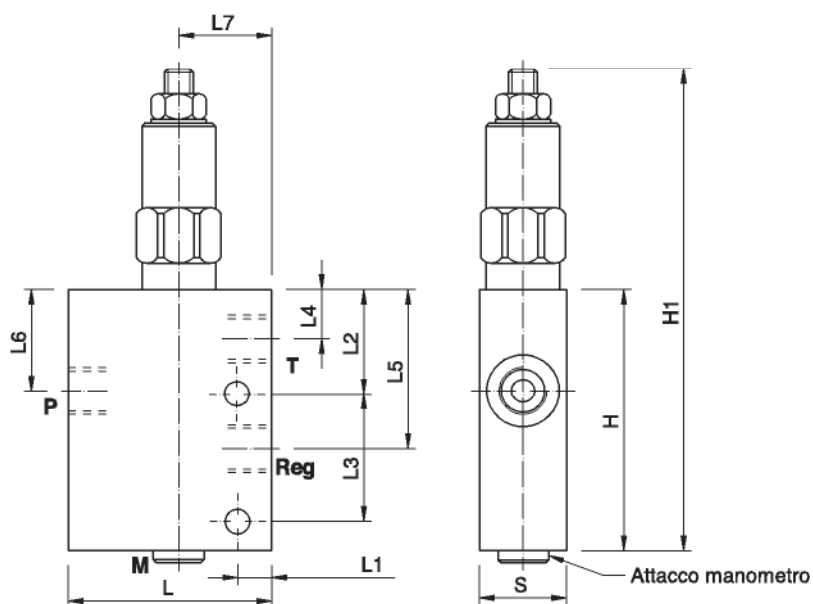

7

CODICE CODE	SIGLA TYPE	P - T - Reg GAS	L mm	L1 mm	L2 mm	L3 mm	L4 mm	L5 mm	L6 mm	L7 mm	H mm	H1 mm	S mm	PESO/ WEIGHT Kg
V0704/000*	VRP 3/8"	3/8"	70	12	36	44	17	55	35	32	90	168	30	1,530
V0706/000*	VRP 1/2"	1/2"	70	12	36	44	17	55	35	32	90	168	30	1,468

CODICE CODE	CAMPO DI TARATURA SETTING RANGE (Bar)
----------------	--

COD/060	10 - 60
COD/180	35 - 180 standard

REGOLAZIONE - ADJUSTEMENT

CODICE/V • CODE/V	Volantino • Handknob
CODICE/PP • CODE/PP	Predisposizione alla piombatura • Arranged for sealing cap
CODICE/P • CODE/P	Piombatura • Sealing cap

VALVOLA RIDUTTRICE DI PRESSIONE DIRETTA CON RITORNO LIBERO

DIRECT ACTING PRESSURE REDUCING VALVE WITH CHECK VALVE

TIPO / TYPE
VRPRL

SCHEMA IDRAULICO
HYDRAULIC DIAGRAM

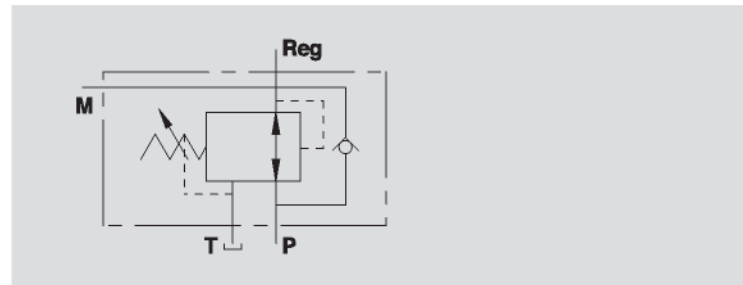
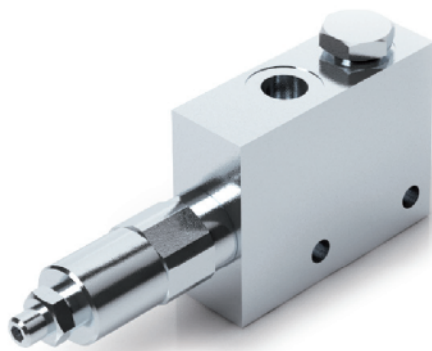

IMPIEGO:

Valvola che permette di mantenere costante la pressione a valle indipendentemente dalla pressione a monte. La presenza della valvola di non ritorno consente il libero ritorno dell'olio.

MATERIALI E CARATTERISTICHE:

Corpo: acciaio zincato.
Componenti interni: acciaio temprato termicamente e rettificato.
Guarnizioni: BUNA N standard.
Trafilamento: 70 cc/min (con 350 Bar alla bocca P).

MONTAGGIO:

Collegare P al circuito principale, Reg. al circuito dove si desidera ridurre la pressione e T allo scarico.

USE AND OPERATION:

This valve maintains a constant downstream pressure irrespective of the upstream pressure. the check valve allows for the free flow of oil in the reverse direction

MATERIALS AND FEATURES:

Body: zinc-plated steel.
Internal parts: hardened and ground steel.
Seals: BUNA N standard.
Leakage: 70 cc/min (350 Bar to port P).

CONNECTIONS:

Connect P to the main circuit, Reg. to the circuit where you want the reduced pressure and T to the tank.

PRESSIONE/PORTATA PRESSURE/FLOW

Temperatura olio: 50°C - Viscosità olio: 30 cSt
Oil temperature: 50° C - Oil viscosity: 30 cSt

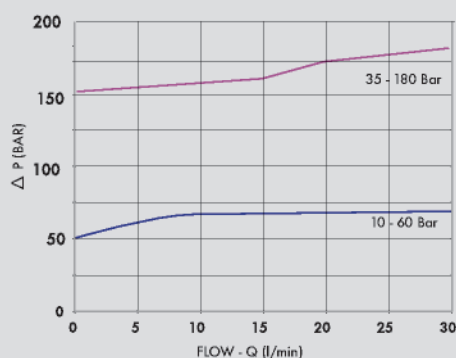



CODICE CODE	SIGLA TYPE	PORTATA MAX MAX FLOW Lt. / min	PRESSIONE MAX MAX PRESSURE Bar
V0705/000*	VRPRL 3/8"	30	350
V0707/000*	VRPRL 1/2"	30	350

*000 = specificare valore della molla desiderata. Vedi tabella sotto.
 *000 = please specify the desired setting range. See the table below.

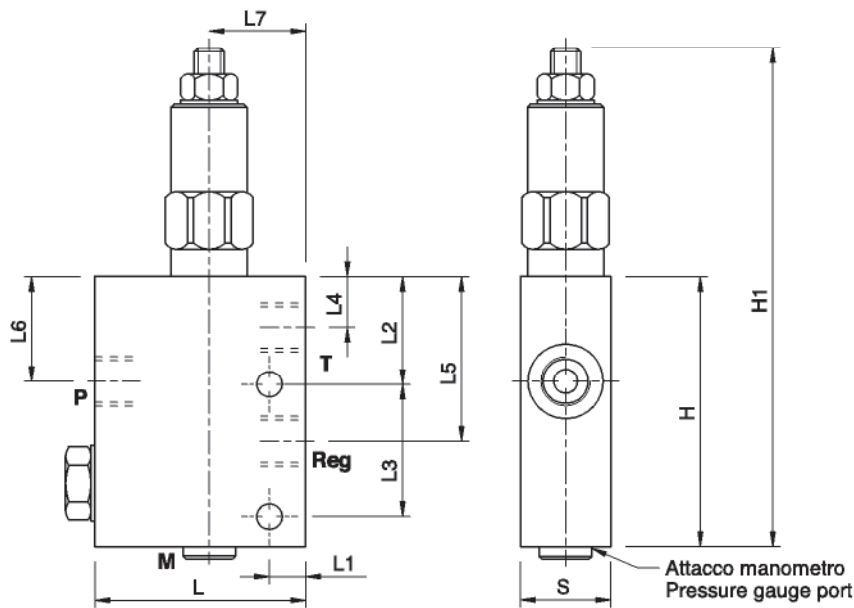

7

CODICE CODE	SIGLA TYPE	P - T - Reg GAS	L mm	L1 mm	L2 mm	L3 mm	L4 mm	L5 mm	L6 mm	L7 mm	H mm	H1 mm	S mm	PESO/ WEIGHT Kg
V0705/000*	VRPRL 3/8"	3/8"	70	12	36	44	17	55	35	32	90	168	30	1,530
V0707/000*	VRPRL 1/2"	1/2"	70	12	36	44	17	55	35	32	90	168	30	1,468

CODICE CODE	CAMPO DI TARATURA SETTING RANGE (Bar)
COD/060	10 - 60
COD/180	35 - 180 standard

REGOLAZIONE - ADJUSTEMENT

CODICE/V • CODE/V	Volantino • Handknob
CODICE/PP • CODE/PP	Predisposizione alla piombatura • Arranged for sealing cap
CODICE/P • CODE/P	Piombatura • Sealing cap