

# HYDRAULIC MOTORS SP

M+S Hydraulic introduces a new version of hydraulic motors, type SP with new housing, integrated output shaft to the spool valve, check valves, high pressure shaft seal. The SP motors are suitable for a wide range of applications where compact and high efficient motors are required.

## CONTENTS

Specification data .....	45÷46
Function diagrams .....	18÷24
Dimensions and mounting .....	47÷48
Shaft extensions .....	48
Permissible shaft Seal Pressure ...	48
Permissible shaft loads .....	49
Order code .....	49

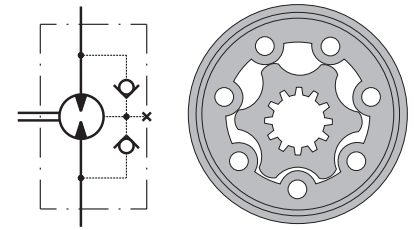

## APPLICATION

- » Conveyors
- » Feeding mechanism of robots and manipulators
- » Metal working machines
- » Textile machines
- » Agriculture machines
- » Food industries
- » Grass cutting machinery etc.

## OPTIONS

- » Model- Spool valve, gerotor
- » Flange mount - 2 hole oval flange; square flange
- » Side BSPP ports
- » Shafts- straight and splined
- » Shaft seal for high and low pressure
- » Other special features

## GENERAL

<b>Max. Displacement,</b> cm <sup>3</sup> /rev [in <sup>3</sup> /rev]	396 [24.16]
<b>Max. Speed,</b> [RPM]	1515
<b>Max. Torque,</b> daNm [lb-in]	cont.:38 [3360] int.: 46 [3240]
<b>Max. Output,</b> kW [HP]	17,5 [23.5]
<b>Max. Pressure Drop,</b> bar [PSI]	cont.:140 [2030] int.:175 [2540]
<b>Max. Oil Flow,</b> lpm [GPM]	75 [19.8]
<b>Min. Speed,</b> [RPM]	10
<b>Pressure fluid</b>	Mineral based- HLP(DIN 51524) or HM(ISO 6743/4)
<b>Temperature range,</b> °C [°F]	-30÷90 [-22÷194]
<b>Optimal Viscosity range,</b> mm <sup>2</sup> /s [SUS]	20÷75 [98÷347]
<b>Filtration</b>	ISO code 20/16 (Min. recommended fluid filtration of 25 micron)

### Oil flow in drain line

Pressure drop bar [PSI]	Viscosity mm <sup>2</sup> /s [SUS]	Oil flow in drain line lpm [GPM]
100 [1450]	20 [98]	2,5 [.660]
	35 [164]	1,8 [.476]
140 [2030]	20 [98]	3,5 [.925]
	35 [164]	2,8 [.740]

### Pressure Losses

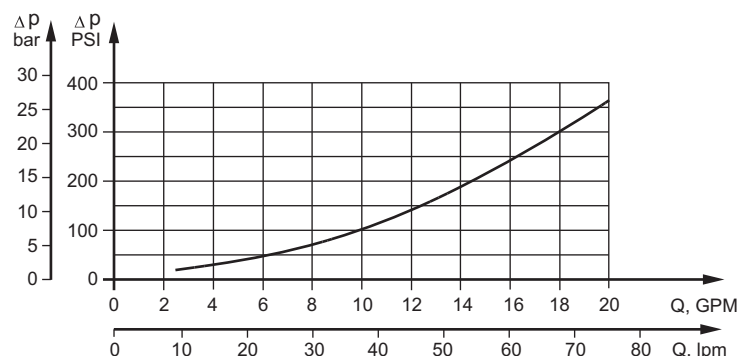

## SPECIFICATION DATA

Specification Data for SP... motors with **C** and **CO** shafts.

Type		SP 50	SP 80	SP 100	SP 125	SP 160	SP 200	SP 250	SP 315	SP 400
<b>Displacement, cm<sup>3</sup>/rev [in<sup>3</sup>/rev]</b>		49,5 [3.0]	79,2 [4.83]	99 [6.04]	123,8 [7.55]	158,4 [9.66]	198 [12.1]	247,5 [15.1]	316,8 [19.3]	396 [2416]
<b>Max. Speed, [RPM]</b>	Cont.	1210	755	605	486	378	303	242	190	150
	Int.*	1515	945	755	605	472	378	303	236	189
<b>Max. Torque daNm [lb-in]</b>	Cont.	9,4 [835]	15,1 [1340]	19,3 [1710]	23,7 [2100]	30 [2655]	30 [2655]	27,6 [2442]	29,5 [2610]	28,5 [2522]
	Int.*	11,9 [1050]	19,5 [1725]	23,7 [2100]	29,8 [2640]	37,8 [3345]	36,5 [3230]	35,5 [3142]	36,6 [4070]	36 [3185]
	Peak**	14 [1240]	22 [1950]	27 [2390]	36,5 [3230]	42 [3717]	53 [4690]	54 [4780]	59 [5222]	59 [5222]
<b>Max. Output kW [HP]</b>	Cont.	9,9 [13.3]	9,9 [13.3]	9,9 [13.3]	9,9 [13.3]	9,9 [13.3]	9,5 [12.7]	6 [8.1]	4 [5.4]	3 [4]
	Int.*	12,5 [16.8]	12,5 [16.8]	12,5 [16.8]	12,5 [16.8]	12,5 [16.8]	12,5 [16.8]	13,2 [17.7]	5,8 [7.8]	5 [6.7]
<b>Max. Pressure Drop bar [PSI]</b>	Cont.	140 [2030]	140 [2030]	140 [2030]	140 [2030]	140 [2030]	115 [1670]	85 [1233]	70 [1015]	55 [798]
	Int.*	175 [2540]	175 [2540]	175 [2540]	175 [2540]	175 [2540]	140 [2030]	110 [1450]	90 [1305]	70 [1015]
	Peak**	225 [3260]	225 [3260]	225 [3260]	225 [3260]	225 [3260]	225 [3260]	180 [2610]	160 [2320]	130 [1885]
<b>Max. Oil Flow lpm [GPM]</b>	Cont.	60 [15.9]	60 [15.9]	60 [15.9]	60 [15.9]	60 [15.9]	60 [15.9]	60 [15.9]	60 [15.9]	60 [15.9]
	Int.*	75 [19.8]	75 [19.8]	75 [19.8]	75 [19.8]	75 [19.8]	75 [19.8]	75 [19.8]	75 [19.8]	75 [19.8]
<b>Max. Starting Pressure with Unloaded Shaft, bar [PSI]</b>		10 [145]	10 [145]	10 [145]	9 [131]	8 [116]	7 [100]	6 [87]	5 [73]	5 [73]
<b>Min. Starting Torque, daNm [lb-in]</b>		7,7 [682]	14 [1240]	16,8 [1490]	21 [1860]	28 [2478]	28,5 [2522]	26,5 [2345]	26,5 [2345]	26,5 [2345]
<b>Max. Inlet Pressure bar [PSI]</b>	Cont.	175 [2540]	175 [2540]	175 [2540]	175 [2540]	175 [2540]	175 [2540]	175 [2540]	175 [2540]	175 [2540]
	Int.*	200 [2900]	200 [2900]	200 [2900]	200 [2900]	200 [2900]	200 [2900]	200 [2900]	200 [2900]	200 [2900]
	Peak**	225 [3260]	225 [3260]	225 [3260]	225 [3260]	225 [3260]	225 [3260]	225 [3260]	225 [3260]	225 [3260]

\* Intermittent operation: the permissible values may occur for max. 10% of every minute.

\*\* Peak load: the permissible values may occur for max. 1% of every minute.

\*\*\* For speeds lower than given, consult factory or your regional manager.

1. Intermittent speed and intermittent pressure must not occur simultaneously.
2. Recommended filtration is per ISO cleanliness code 20/16. A nominal filtration of 25 micron or better.
3. Recommend using a premium quality, anti-wear type mineral based hydraulic oil HLP (DIN51524) or HM (ISO 6743/4).  
If using synthetic fluids consult the factory for alternative seal materials.
4. Recommended minimum oil viscosity 13 mm<sup>2</sup>/s [70 SUS] at 50°C [122°F].
5. Recommended maximum system operating temperature is 82°C [180°F].
6. To assure optimum motor life fill with fluid prior to loading and run at moderate load and speed for 10-15 minutes.

## SPECIFICATION DATA

Specification Data for SP... motors with **SH** shafts.

Type		SP 50	SP 80	SP 100	SP 125	SP 160	SP 200	SP 250	SP 315	SP 400
<b>Displacement, cm<sup>3</sup>/rev [in<sup>3</sup>/rev]</b>		49,5 [3.0]	79,2 [4.83]	99 [6.04]	123,8 [7.55]	158,4 [9.66]	198 [12.1]	247,5 [15.1]	316,8 [19.3]	396 [2416]
<b>Max. Speed, [RPM]</b>	Cont.	1210	755	605	486	378	303	242	190	150
	Int.*	1515	945	755	605	472	378	303	236	189
<b>Max. Torque daNm [lb-in]</b>	Cont.	9,4 [835]	15,1 [1340]	19,3 [1710]	23,7 [2100]	30 [2655]	36,6 [3240]	38 [3360]	38 [3360]	36 [3190]
	Int.*	11,9 [1050]	19,5 [1725]	23,7 [2100]	29,8 [2640]	37,8 [3345]	45,6 [4035]	45 [3980]	46 [3240]	46 [3240]
	Peak**	14 [1240]	22 [1950]	27 [2390]	36,5 [3230]	42 [3717]	53 [4690]	67 [5930]	85 [7523]	85 [7523]
<b>Max. Output kW [HP]</b>	Cont.	9,9 [13.3]	9,9 [13.3]	9,9 [13.3]	9,9 [13.3]	9,9 [13.3]	10,3 [13.8]	8 [10.7]	6 [8.1]	4,8 [6.4]
	Int.*	12,5 [16.8]	12,5 [16.8]	12,5 [16.8]	12,5 [16.8]	12,5 [16.8]	15,3 [20.5]	17,5 [23.5]	8,2 [10.9]	9,2 [12.3]
<b>Max. Pressure Drop bar [PSI]</b>	Cont.	140 [2030]	140 [2030]	140 [2030]	140 [2030]	140 [2030]	140 [2030]	110 [1450]	90 [1305]	70 [1015]
	Int.*	175 [2540]	175 [2540]	175 [2540]	175 [2540]	175 [2540]	175 [2540]	140 [2030]	140 [2030]	90 [1305]
	Peak**	225 [3260]	225 [3260]	225 [3260]	225 [3260]	225 [3260]	225 [3260]	225 [3260]	225 [3260]	180 [2610]
<b>Max. Oil Flow lpm [GPM]</b>	Cont.	60 [15.9]	60 [15.9]	60 [15.9]	60 [15.9]	60 [15.9]	60 [15.9]	60 [15.9]	60 [15.9]	60 [15.9]
	Int.*	75 [19.8]	75 [19.8]	75 [19.8]	75 [19.8]	75 [19.8]	75 [19.8]	75 [19.8]	75 [19.8]	75 [19.8]
<b>Max. Starting Pressure with Unloaded Shaft, bar [PSI]</b>		10 [145]	10 [145]	10 [145]	9 [131]	8 [116]	7 [100]	6 [87]	5 [73]	5 [73]
<b>Min. Starting Torque, daNm [lb-in]</b>		7,7 [682]	14 [1240]	16,8 [1490]	21 [1860]	28 [2478]	34,6 [3062]	34,5 [3050]	35 [3098]	35 [3098]
<b>Max. Inlet Pressure bar [PSI]</b>	Cont.	175 [2540]	175 [2540]	175 [2540]	175 [2540]	175 [2540]	175 [2540]	175 [2540]	175 [2540]	175 [2540]
	Int.*	200 [2900]	200 [2900]	200 [2900]	200 [2900]	200 [2900]	200 [2900]	200 [2900]	200 [2900]	200 [2900]
	Peak**	225 [3260]	225 [3260]	225 [3260]	225 [3260]	225 [3260]	225 [3260]	225 [3260]	225 [3260]	225 [3260]

\* Intermittent operation: the permissible values may occur for max. 10% of every minute.

\*\* Peak load: the permissible values may occur for max. 1% of every minute.

\*\*\* For speeds lower than given, consult factory or your regional manager.

1. Intermittent speed and intermittent pressure must not occur simultaneously.
2. Recommended filtration is per ISO cleanliness code 20/16. A nominal filtration of 25 micron or better.
3. Recommend using a premium quality, anti-wear type mineral based hydraulic oil HLP(DIN51524) or HM ( ISO 6743/4).  
If using synthetic fluids consult the factory for alternative seal materials.
4. Recommended minimum oil viscosity 13 mm<sup>2</sup>/s [70 SUS] at 50°C [122°F].
5. Recommended maximum system operating temperature is 82°C [180°F].
6. To assure optimum motor life fill with fluid prior to loading and run at moderate load and speed for 10-15 minutes.

**DIMENSIONS AND MOUNTING DATA**

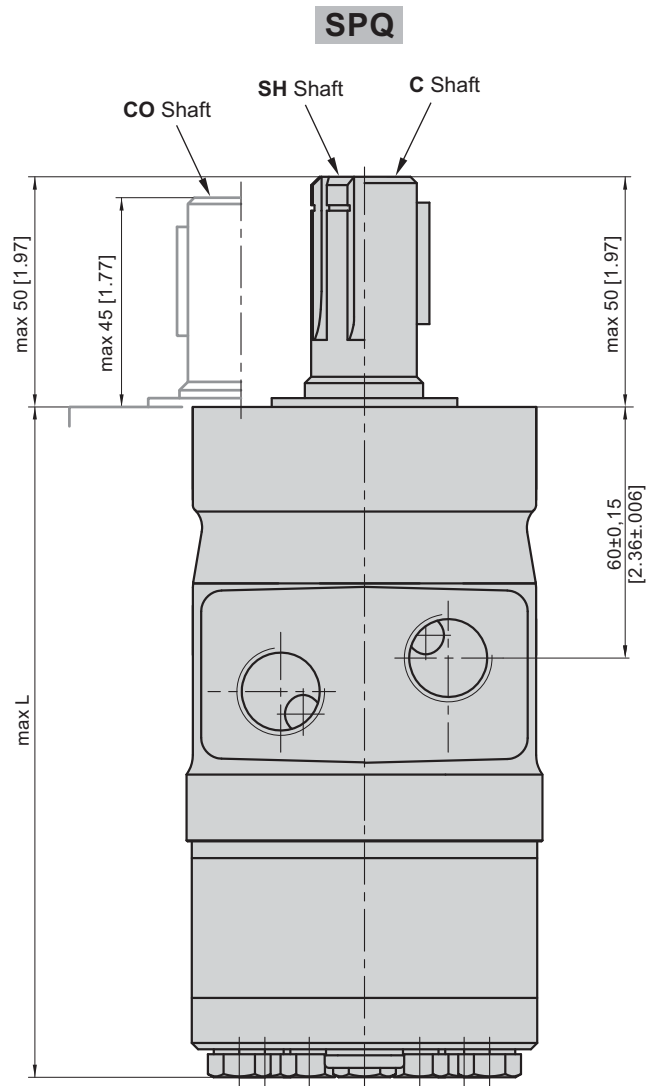
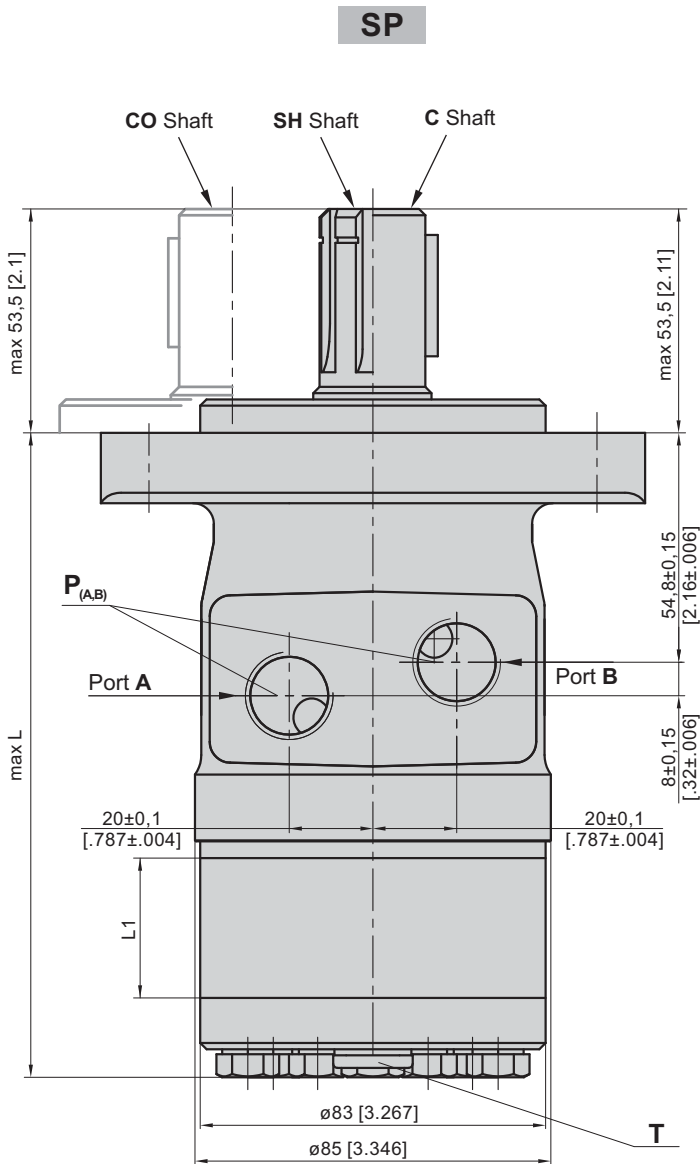

**P<sub>(A,B)</sub>**: 2xG1/2 - 18 mm [.709 in] depth  
**T**: G1/4 - 12 mm [.47 in] depth

Type	L <sub>max</sub> , mm [in]	Type	L <sub>max</sub> , mm [in]	L <sub>1</sub> , mm [in]
SP 50	128 [5.04]	SPQ 50	134 [5.28]	6,67 [.26]
SP 80	132 [5.19]	SPQ 80	138 [5.43]	10,67 [.42]
SP 100	134,5 [5.29]	SPQ 100	140,9 [5.55]	13,33 [.52]
SP 125	138 [5.43]	SPQ 125	144 [5.67]	16,67 [.66]
SP 160	142,5 [5.61]	SPQ 160	148,9 [5.86]	21,33 [.84]
SP 200	148 [5.83]	SPQ 200	154 [6.06]	26,67 [1.05]
SP 250	154,5 [6.08]	SPQ 250	160,9 [6.33]	33,33 [1.31]
SP 315	164 [6.46]	SPQ 315	170 [6.69]	42,67 [1.68]
SP 400	174,5 [6.87]	SPQ 400	180,9 [7.12]	53,33 [2.10]

**Standard Rotation**  
 Viewed from Shaft End  
 Port A Pressurized - **CW**  
 Port B Pressurized - **CCW**

**Reverse Rotation**  
 Viewed from Shaft End  
 Port A Pressurized - **CCW**  
 Port B Pressurized - **CW**



**MOUNTING**

Oval Mount (2 Holes)

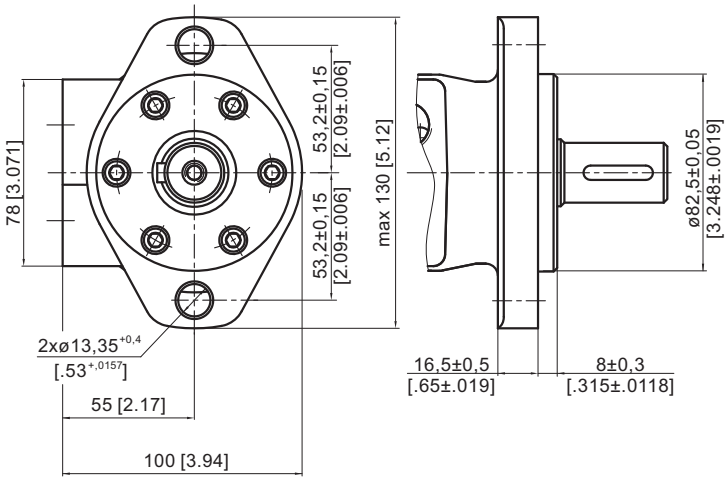

**Q** Square Mount (4 bolts)

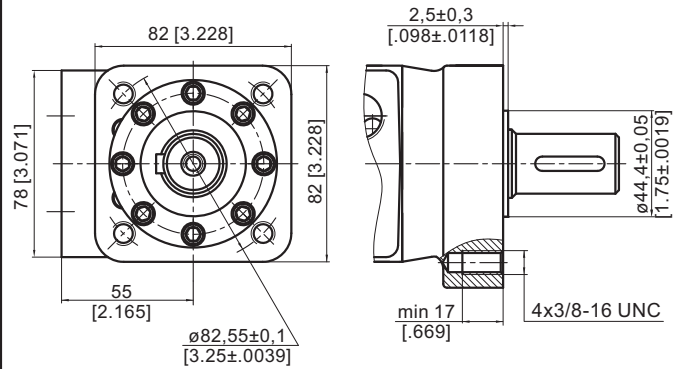

**SHAFT EXTENSIONS**

**C** - ø25 straight, Parallel key A8x7x30 DIN 6885  
Max. Torque 34 daNm [3010 lb-in]

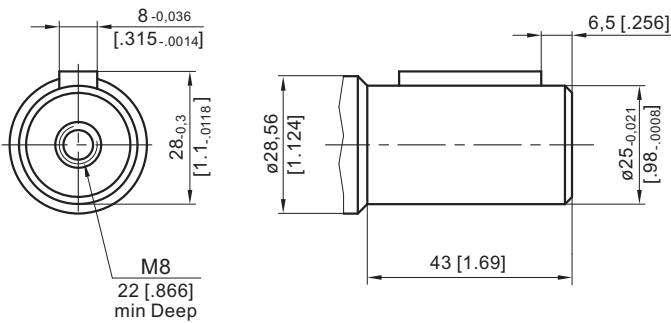

**CO** - ø1" straight, Parallel key 1/4"x1/4"x1" BS46  
Max. Torque 34 daNm [3010 lb-in]

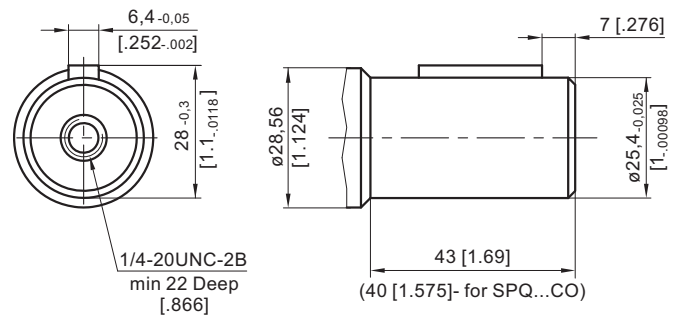

**SH** - splined, BS 2059 (SAE 6B)  
Max. Torque 40 daNm [3540 lb-in]

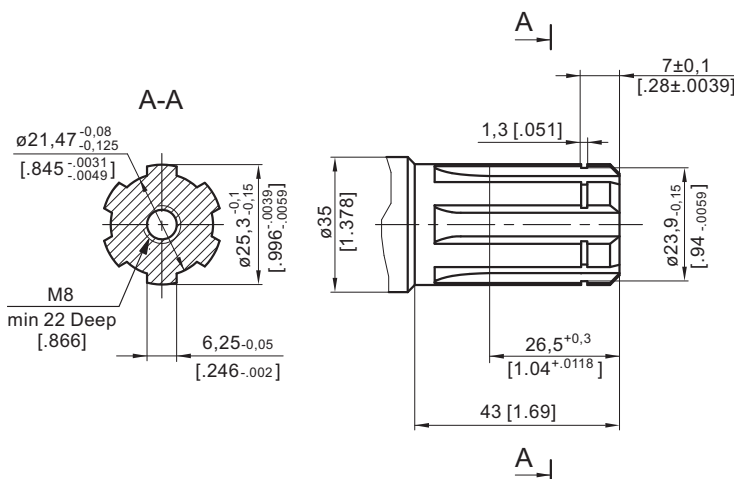

**MAX. PERMISSIBLE SHAFT SEAL PRESSURE**

Max return pressure without drain line or max. pressure in drain line

— - continuous operations  
- - - - intermittent operations

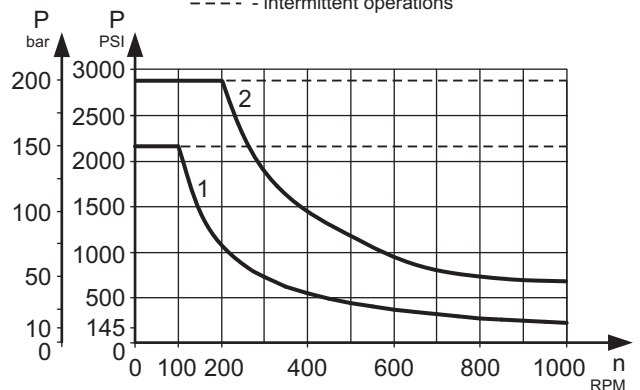

1: Curve for Standard Shaft Seal

2: Curve for High Pressure Seal ("U" Seal)



**PERMISSIBLE SHAFT LOADS**

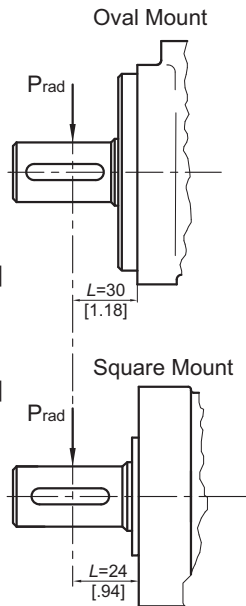

$P_{max}=150 \text{ daN}$   
[330 lbs]

$P_{max}=200 \text{ daN}$   
[440 lbs]

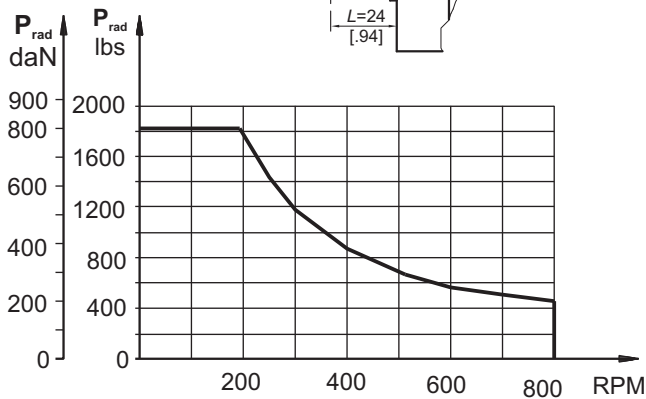

Radial Shaft Load  $P_{rad}$  for C, CO Shaft Extensions by  $L=30 \text{ mm}$  [1.18 in] (24 mm [0.94 in])

The permissible radial shaft load depends on

- Speed (n)
- Distance (L) from the pointload to the mounting flange
- Mounting flange version

$$\text{Oval mount: } P_{rad} = \frac{800}{n} \times \frac{24300}{91,5+L} \text{ [daN]}^*$$

$$\left[ \frac{800}{\text{RPM}} \times \frac{2150}{3.6+L} \text{ [lbs]} \right]$$

$$\text{Square mount: } P_{rad} = \frac{800}{n} \times \frac{24300}{97,5+L} \text{ [daN]}^*$$

$$\left[ \frac{800}{\text{RPM}} \times \frac{2150}{3.84+L} \text{ [lbs]} \right]$$

\*  $n \leq 200 \text{ RPM}$ ; max  $P_{rad}=800 \text{ daN}$  [1800lbs]

$n \geq 200 \text{ RPM}$ ;  $L < 55 \text{ mm}$  [2.2 in]

**ORDER CODE**

1	2	3	4	5	6
<b>SP</b>					

**Pos.1 - Mounting Flange**

omit - Oval mount, two holes

**Q** - Square mount, four bolts - 3/8-16 UNC

**Pos.2 - Displacement code\***

<b>50</b>	- 49,5 cm <sup>3</sup> /rev [ 3.02 in <sup>3</sup> /rev]
<b>80</b>	- 79,2 cm <sup>3</sup> /rev [ 4.83 in <sup>3</sup> /rev]
<b>100</b>	- 99,0 cm <sup>3</sup> /rev [ 6.04 in <sup>3</sup> /rev]
<b>125</b>	- 123,8 cm <sup>3</sup> /rev [ 7.55 in <sup>3</sup> /rev]
<b>160</b>	- 158,4 cm <sup>3</sup> /rev [ 9.66 in <sup>3</sup> /rev]
<b>200</b>	- 198,0 cm <sup>3</sup> /rev [12.10 in <sup>3</sup> /rev]
<b>250</b>	- 247,5 cm <sup>3</sup> /rev [15.10 in <sup>3</sup> /rev]
<b>315</b>	- 316,8 cm <sup>3</sup> /rev [19.30 in <sup>3</sup> /rev]
<b>400</b>	- 396,0 cm <sup>3</sup> /rev [24.16 in <sup>3</sup> /rev]

**Pos.3 - Shaft Extensions\*\***

**C** -  $\varnothing 25$  straight, Parallel key A8x7x30 DIN6885

**CO** -  $\varnothing 1$ " straight, Parallel key  $1/4$ "x $1/4$ "x $1/4$ " BS46

**SH** -  $\varnothing 25,3$  splined, BS 2059 (SAE 6B)

**Pos.4 - Shaft Seal Version**

omit - Standard shaft seal

**U** - High pressure shaft seal

**Pos.5 - Special Features (see page 119)**

**Pos.6 - Design Series**

omit - Factory specified

**NOTES:**

\* For the Function Diagrams data please look at "M+S Hydraulic" Catalogue for MP motors, pages 18÷24.

\*\* The permissible output torque for shafts must not be exceeded!

The hydraulic motors are manganophosphatized as standard.