

TRAPEZOIDAL SCREWS

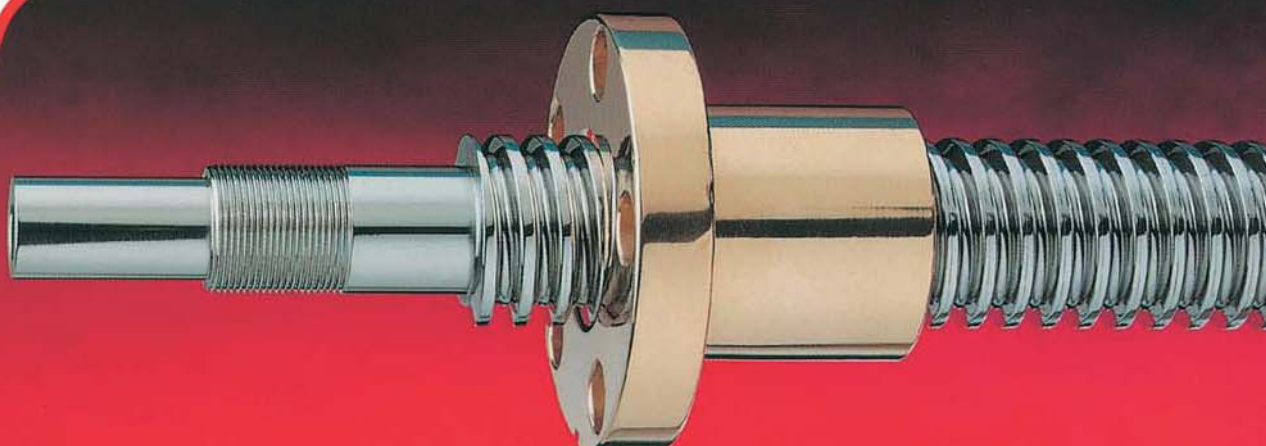

PROFILE FOR METRIC TRAPEZOIDAL THREADS TO ISO STANDARD 2901 – 2902 – 2903 – 2904

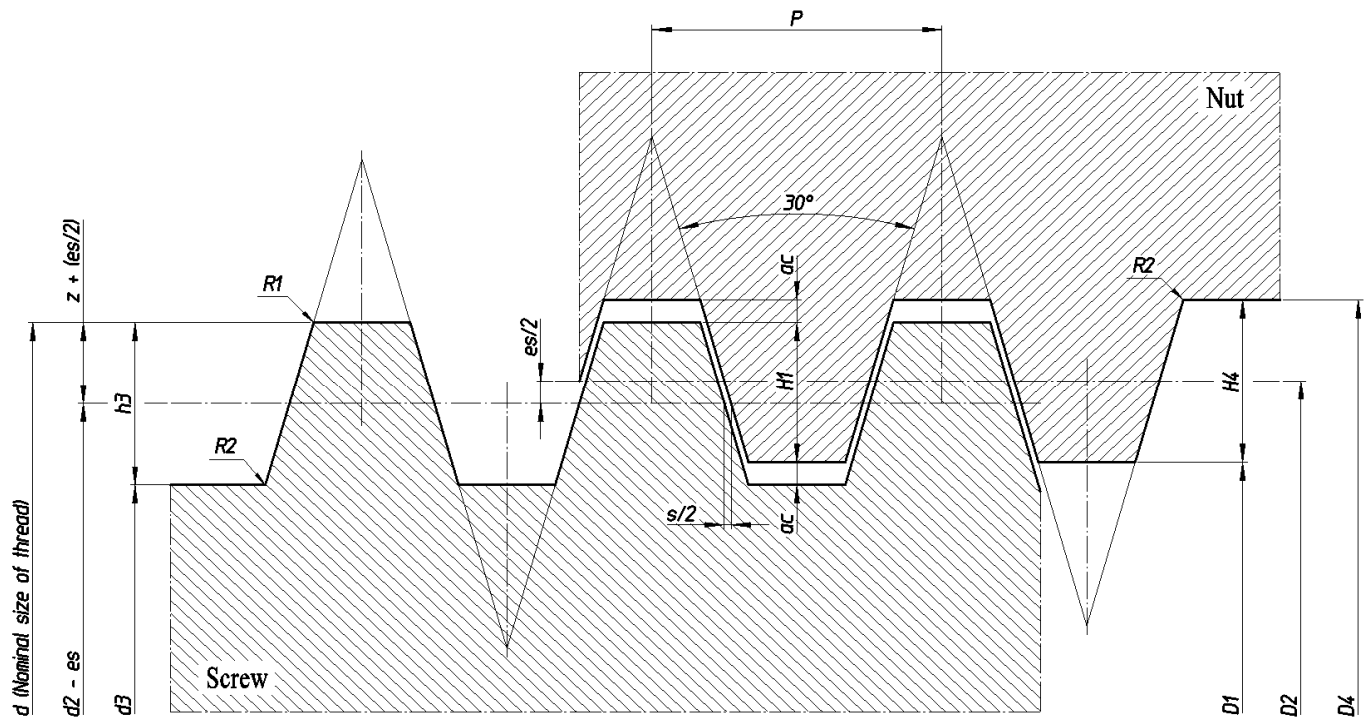

$$H_1 = 0,5 P$$

$$h_3 = H_4 = H_1 + a_c = 0.5 P + a_c$$

$$z = 0,25 P = H_1/2$$

$$d_3 = d - 2 h_3$$

$$d_2 = D_2 = d - 2 z = d - 0.5 P$$

$$D_2 = d + 2 a_c$$

a_c = bottom play
 es = top deviation for screw
 $s = 0,26795 es$
 $R_1 \text{ max.} = 0.5 a_c$
 $R_2 \text{ max.} = a_c$

Sizes stocked. Ready reference:

Screws..... page 6
Nuts..... page 10

Generale features and materials used in “Conti” precision

Rolled trapezoidal screws and nuts..... page 16

Screw	Lead Accuracy	Material	
KTS	100	carbon steel	EN 10083-2 1C45 – 1.0503..... page 18
KUE	100	carbon steel	EN 10083-2 1C45 – 1.0503..... page 19
KKA	50	carbon steel	EN 10083-2 1C45 – 1.0503..... page 20
KSR	500	carbon steel	EN 10083-2 1C45 – 1.0503..... page 21
KQX	200	carbon steel	EN 10084 C15E – 1.1141..... page 22
KEQ	200	carbon steel	EN 10084 C15E – 1.1141..... page 23
KRP	200	stainless steel	INOX A2 - AISI 304 – 1.4301..... page 24
KRE	200	stainless steel	INOX A2 - AISI 304 – 1.4301..... page 25
KAM	200	stainless steel	INOX A4 - AISI 316 – 1.4401..... page 26
KAF	200	stainless steel	INOX A4 - AISI 316 – 1.4401..... page 27

Nut	Shape	Material	
MLF	cylindrical	steel	EN 10277-3 11SMnPb37 – 1.0737..... page 33
MZP	cylindrical	steel	EN 10277-3 11SMnPb37 – 1.0737..... page 33
HSN	cylindrical	bronze	EN 1982 CuSn5Zn5Pb5-C – CC491K..... page 34
HBD	cylindrical	bronze	EN 1982 CuSn7Zn4Pb7-C – CC493K..... page 34
HDA	cylindrical	stainless steel	INOX A1- AISI 303 – 1.4305..... page 35
HBM	cylindrical	bronze	EN 1982 CuSn12-C – CC483K..... page 35
BIG	cylindrical big	bronze	EN 1982 CuSn12-C – CC483K..... page 36
CQA	square	steel	EN 10277-3 11SMnPb37 – 1.0737..... page 37
QOB	square	brass	EN 12164 CW614N-M (ex OT58)..... page 37
CQF	square holes	steel	EN 10277-3 11SMnPb37 – 1.0737..... page 38
QBF	square holes	bronze	EN 1982 CuSn12-C – CC483K..... page 39
FTN	flanged	bronze	EN 1982 CuSn5Zn5Pb5-C – CC491K..... page 40
FXN	flanged	bronze	EN 1982 CuSn12-C – CC483K..... page 41
FMT	flanged	bronze	EN 1982 CuSn12-C – CC483K..... page 42
HDL	flanged	bronze	EN 1982 CuSn12-C – CC483K..... page 43
CBC	flanged	bronze	EN 1982 CuSn12-C – CC483K..... page 44
FFR	flanged	bronze	EN 1982 CuSn12-C – CC483K..... page 45
FHD	flanged	bronze	EN 1982 CuSn12-C – CC483K..... page 46
CDF	2-flanged	bronze	EN 1982 CuSn12-C – CC483K..... page 47
HAL	flanged	Alu. bronze	EN 1982 CuAl11Fe6Ni6-C – CC483K..... page 48
MES	exagonal	steel	EN 10277-3 11SMnPb37 – 1.0737..... page 49
FCS	flanged	plastic	PA 6 + Mo S2 DIN 7728 + self lubricating.... page 50
MPH	cylindrical	plastic	PA 6 + Mo S2 DIN 7728..... page 51

Specifications:

Screws page 52
Nuts page 54

General choice criteria page 56

General sizing criteria page 57

Use of bronze nuts:

Sizing and example of calculation page 58

Use of plastic nuts:

Sizing and example of calculation page 61

Duration and example of calculation page 65

Critical axial load (peak load) page 67

Critical revolutions per minute page 68

Efficiency page 69

Torque and Power page 70

Stock numbers for ordering:

Screws page 71

Nuts page 73

Comment Card page 74

TRAPEZOIDAL SCREWS

Single start	Carbon Steel											
	C45								C15			
	KTS accuracy 100 page 18		KUE page 19		KKA accuracy 50 page 20		KSR accuracy 500 page 21		KQX accuracy 200 page 22		KEQ accuracy 200 page 23	
THREAD	RH	LH	RH	LH	RH	LH	RH	LH	RH	LH	RH	LH
Tr 10 x 2	■	■	■	■	□	□	□	□	■	□	■	□
Tr 10 x 3	■	■	■	■	□	□	□	□	■	■	■	□
Tr 12 x 3	■	■	■	■	□	□	□	□	■	■	■	□
Tr 14 x 3	■	■	■	■	□	□	□	□	■	□	■	□
Tr 14 x 4	■	■	■	■	□	□	□	□	■	■	■	□
Tr 16 x 4	■	■	■	■	■	□	□	□	■	■	■	□
Tr 18 x 4	■	■	■	■	□	□	□	□	■	■	■	□
Tr 20 x 4	■	■	■	■	■	□	□	□	■	■	■	□
Tr 22 x 5	■	■	■	■	□	□	□	□	■	■	■	□
Tr 24 x 5	■	■	■	■	□	□	□	□	■	■	■	□
Tr 25 x 3	■	□	■	□			□	□	□	□	□	□
Tr 25 x 5	■	■	■	■	■	□	□	□	■	■	□	□
Tr 26 x 5	■	■	■	■	□	□	□	□	■	■	■	□
Tr 28 x 5	■	■	■	■	■	□	□	□	■	■	■	□
Tr 30 x 3							□	□	■	■	□	□
Tr 30 x 4							□	□	■	■	□	□
Tr 30 x 5	□	□	□	□	□	□	□	□	■	■	□	□
Tr 30 x 6	■	■	■	■	■	□	□	□	■	■	■	□
Tr 32 x 6	■	■	■	■	□	□	□	□	■	■	■	□
Tr 35 x 3							□	□	■	■	□	□
Tr 35 x 4							□	□	■	■	□	□
Tr 35 x 5	□	□	□	□	□	□	□	□	■	■	□	□
Tr 35 x 6	■	■	■	■	■	□	□	□	■	■	□	□
Tr 35 x 8	■	□	■	□	□	□	□	□	□	□	□	□
Tr 36 x 6	■	■	■	■	□	□	□	□	■	■	■	□
Tr 40 x 3							□	□	■	■	□	□
Tr 40 x 4							□	□	■	■	□	□
Tr 40 x 5	□	□	□	□	□	□	□	□	■	■	□	□
Tr 40 x 6	■	■	■	■	□	□	□	□	□	□	□	□
Tr 40 x 7	■	■	■	■	■	□	□	□	■	■	■	□
Tr 40 x 8	■	□	■	□	□	□	□	□	□	□	□	□
Tr 40 x 10	■	□	■	□	□	□	□	□	□	□	□	□
Tr 44 x 7	■	■	■	■	□	□	□	□	■	■	■	□
Tr 45 x 8	■	■	■	■	□	□	□	□	■	■	□	□
Tr 50 x 3							□	□	■	■	□	□
Tr 50 x 4							□	□	■	■	□	□
Tr 50 x 5	□	□	□	□	□	□	□	□	■	■	□	□
Tr 50 x 6	□	□	□	□	□	□	□	□	■	■	□	□
Tr 50 x 8	■	■	■	■	■	□	□	□	■	■	■	□
Tr 50 x 10	■	□	■	□	□	□	□	□	■	□	□	□
Tr 55 x 9	■	□	■	□	□	□	□	□	■	□	■	□
Tr 60 x 6	□	□	□	□	□	□	□	□	■	■	□	□
Tr 60 x 7	□	□	□	□	□	□	□	□	■	■	□	□
Tr 60 x 9	■	■	■	■	□	□	□	□	■	■	■	□
Tr 70 x 10	■	■	■	■	□	□	□	□	■	□	■	□
Tr 80 x 10	■	■	■	■	□	□	□	□	■	□	■	□
Tr 90 x 12	■	□	■	□								
Tr 95 x 16	■	□	■	□								
Tr 100 x 12	■	□	■	□								
Tr 100 x 16	■	□	■	□								
Tr 120 x 14	■	□	■	□								
Tr 120 x 16	■	□	■	□								
Tr 140 x 14	■	□	■	□								

■ = Goods in stock.

□ = Goods available upon request only.

SINGLE START

Single start	Stainless Steel							
	INOX A2				INOX A4			
	KRP accuracy 200 page 24		KRE accuracy 200 page 25		KAM accuracy 200 page 26		KAF accuracy 200 page 27	
THREAD	RH	LH	RH	LH	RH	LH	RH	LH
Tr 10 x 2	☐	☐	☐	☐	■	☐	■	☐
Tr 10 x 3	☐	☐	☐	☐	☐	☐	☐	☐
Tr 12 x 3	■	■	■	■	■	■	■	■
Tr 14 x 3	☐	☐	☐	☐	■	☐	■	☐
Tr 14 x 4	■	■	■	■	☐	☐	☐	☐
Tr 16 x 4	■	■	■	■	■	■	■	■
Tr 18 x 4	■	■	■	■	■	☐	■	☐
Tr 20 x 4	■	■	■	■	■	■	■	■
Tr 22 x 5	☐	☐	☐	☐	■	☐	■	☐
Tr 24 x 5	■	■	■	■	■	■	■	■
Tr 25 x 3								
Tr 25 x 5	■	■	■	■	☐	☐	☐	☐
Tr 26 x 5	■	☐	■	☐	■	☐	■	☐
Tr 28 x 5	■	☐	■	☐	■	☐	■	☐
Tr 30 x 3								
Tr 30 x 4								
Tr 30 x 5	☐	☐	☐	☐	☐	☐	☐	☐
Tr 30 x 6	■	■	■	■	■	■	■	■
Tr 32 x 6	☐	☐	☐	☐	■	■	■	■
Tr 35 x 3								
Tr 35 x 4								
Tr 35 x 5	☐	☐	☐	☐	☐	☐	☐	☐
Tr 35 x 6	■	■	■	■	☐	☐	☐	☐
Tr 35 x 8								
Tr 36 x 6	■	■	■	■	■	■	■	■
Tr 40 x 3								
Tr 40 x 4								
Tr 40 x 5	☐	☐	☐	☐	☐	☐	☐	☐
Tr 40 x 6	☐	☐	☐	☐	☐	☐	☐	☐
Tr 40 x 7	■	■	■	■	■	■	■	■
Tr 40 x 8								
Tr 40 x 10								
Tr 44 x 7	☐	☐	☐	☐	☐	☐	☐	☐
Tr 45 x 8								
Tr 50 x 3								
Tr 50 x 4								
Tr 50 x 5	☐	☐	☐	☐	☐	☐	☐	☐
Tr 50 x 6	☐	☐	☐	☐	☐	☐	☐	☐
Tr 50 x 8	■	■	■	■	■	■	■	■
Tr 50 x 10								
Tr 55 x 9	☐	☐	☐	☐	☐	☐	☐	☐
Tr 60 x 6	☐	☐	☐	☐	☐	☐	☐	☐
Tr 60 x 7	☐	☐	☐	☐	☐	☐	☐	☐
Tr 60 x 9	■	■	■	■	■	■	■	■
Tr 70 x 10	■	■	■	■	■	■	■	■
Tr 80 x 10	■	■	■	■	■	■	■	■
Tr 90 x 12	■	☐	■	☐	■	☐	■	☐
Tr 95 x 16								
Tr 100 x 12	■	☐	■	☐	■	☐	■	☐
Tr 100 x 16								
Tr 120 x 14								
Tr 120 x 16								
Tr 140 x 14								

■ = Goods in stock.

☐ = Goods available upon request only.

TRAPEZOIDAL SCREWS

Multiple start	Carbon Steel									
	C45						C15			
	KTS accuracy 100 page 28		KUE page 28		KKA accuracy 50 page 29		KQX accuracy 200 page 30		KEQ accuracy 200 page 30	
THREAD	RH	LH	RH	LH	RH	LH	RH	LH	RH	LH
Tr 10 x 4 (P2)	■	□	■	□	□	□	□	□	□	□
Tr 12 x 6 (P3)	■	□	■	□	□	□	■	□	□	□
Tr 14 x 6 (P3)	■	□	■	□	□	□	□	□	□	□
Tr 16 x 8 (P4)	■	□	■	□	□	□	■	□	□	□
Tr 18 x 8 (P4)	■	□	■	□	□	□	□	□	□	□
Tr 20 x 8 (P4)	■	□	■	□	□	□	■	□	□	□
Tr 20 x 20 (P5)	□	□	□	□	□	□	■	□	□	□
Tr 22 x 10 (P5)	■	□	■	□	□	□	□	□	□	□
Tr 24 x 10 (P5)	■	□	■	□	□	□	□	□	□	□
Tr 25 x 10 (P5)	□	□	□	□	□	□	■	□	□	□
Tr 25 x 25 (P5)	■	□	■	□	□	□	■	□	□	□
Tr 26 x 10 (P5)	■	□	■	□	□	□	□	□	□	□
Tr 28 x 10 (P5)	■	□	■	□	□	□	■	□	□	□
Tr 30 x 12 (P6)	■	□	■	□	□	□	■	□	□	□
Tr 30 x 30 (P5)	□	□	□	□	□	□	■	□	□	□
Tr 32 x 12 (P6)	■	□	■	□	□	□	□	□	□	□
Tr 36 x 12 (P6)	■	□	■	□	□	□	□	□	□	□
Tr 40 x 14 (P7)	■	□	■	□	□	□	■	□	□	□
Tr 40 x 40 (P8)	□	□	□	□	□	□	■	□	□	□

■ = Goods in stock.

□ = Goods available upon request only.







MULTIPLE START

Multiple start	Stainless Steel							
	INOX A2				INOX A4			
	KRP accuracy 200 page 31		KRE accuracy 200 page 31		KAM accuracy 200 page 32		KAF accuracy 200 page 32	
THREAD	RH	LH	RH	LH	RH	LH	RH	LH
Tr 10 x 4 (P2)	☐	☐	☐	☐	☐	☐	☐	☐
Tr 12 x 6 (P3)	■	☐	■	☐	☐	☐	☐	☐
Tr 14 x 6 (P3)	☐	☐	☐	☐	☐	☐	☐	☐
Tr 16 x 8 (P4)	■	☐	■	☐	☐	☐	☐	☐
Tr 18 x 8 (P4)	☐	☐	☐	☐	☐	☐	☐	☐
Tr 20 x 8 (P4)	■	☐	■	☐	☐	☐	☐	☐
Tr 20 x 20 (P5)	☐	☐	☐	☐	☐	☐	☐	☐
Tr 22 x 10 (P5)	☐	☐	☐	☐	☐	☐	☐	☐
Tr 24 x 10 (P5)	☐	☐	☐	☐	☐	☐	☐	☐
Tr 25 x 10 (P5)	■	☐	■	☐	☐	☐	☐	☐
Tr 25 x 25 (P5)								
Tr 26 x 10 (P5)	☐	☐	☐	☐	☐	☐	☐	☐
Tr 28 x 10 (P5)	☐	☐	☐	☐	☐	☐	☐	☐
Tr 30 x 12 (P6)	■	☐	■	☐	☐	☐	☐	☐
Tr 30 x 30 (P5)								
Tr 32 x 12 (P6)	☐	☐	☐	☐	☐	☐	☐	☐
Tr 36 x 12 (P6)	☐	☐	☐	☐	☐	☐	☐	☐
Tr 40 x 14 (P7)	■	☐	■	☐	☐	☐	☐	☐
Tr 40 x 40 (P8)								

■ = Goods in stock.





☐ = Goods available upon request only.

TRAPEZOIDAL NUTS

Single start	MLF page 33 Steel 11SMnPb37		MZP page 33 Steel 11SMnPb37		HDA page 35 Stainless Steel Aisi 303 1.4305		HSN page 34 Bronze CuSn5Zn5Pb5-C		HBD page 34 Bronze CuSn7Zn4Pb7-C		HBM page 35 Bronze CuSn12-C	
												
THREAD	RH	LH	RH	LH	RH	LH	RH	LH	RH	LH	RH	LH
Tr 10 x 2			■	■					■	■		
Tr 10 x 3			■	■					■	■	■	■
Tr 12 x 3	■	■	■	■	■	■	■	■	■	■	■	■
Tr 14 x 3			■	■					■	■		
Tr 14 x 4	■	■	■	■	■	■	■	■	■	■	■	■
Tr 16 x 4	■	■	■	■	■	■	■	■	■	■	■	■
Tr 18 x 4	■	■	■	■			■	■	■	■	■	■
Tr 20 x 4	■	■	■	■	■	■	■	■	■	■	■	■
Tr 22 x 5	■	■	■	■			■	■	■	■		
Tr 24 x 5			■	■	■	■			■	■		
Tr 25 x 3												
Tr 25 x 5	■	■					■	■			■	■
Tr 26 x 5			■	■					■	■		
Tr 28 x 5	■	■	■	■			■	■	■	■		
Tr 30 x 3												
Tr 30 x 4												
Tr 30 x 5												
Tr 30 x 6	■	■	■	■	■	■	■	■	■	■	■	■
Tr 32 x 6			■	■					■	■		
Tr 35 x 3												
Tr 35 x 4												
Tr 35 x 5												
Tr 35 x 6	■	■					■	■			■	■
Tr 35 x 8												
Tr 36 x 6			■	■	■	■			■	■	■	■
Tr 40 x 3												
Tr 40 x 4												
Tr 40 x 5												
Tr 40 x 6												
Tr 40 x 7	■	■	■	■	■	■	■	■	■	■	■	■
Tr 40 x 8												
Tr 40 x 10												
Tr 44 x 7			■	■					■	■		
Tr 45 x 8	■	■					■	■			■	■
Tr 50 x 3												
Tr 50 x 4												
Tr 50 x 5												
Tr 50 x 6												
Tr 50 x 8	■	■	■	■	■	■	■	■	■	■	■	■
Tr 50 x 10												
Tr 55 x 9	■						■				■	
Tr 60 x 6												
Tr 60 x 7												
Tr 60 x 9	■	■	■	■			■	■	■	■	■	■
Tr 70 x 10			■	■					■	■	■	■
Tr 80 x 10			■	■					■	■	■	■
Tr 90 x 12												
Tr 95 x 16												
Tr 100 x 12												
Tr 100 x 16												
Tr 120 x 14												
Tr 120 x 16												
Tr 140 x 14												





■ = Goods in stock

SINGLE START

Single start	BIG page 36 Bronze CuSn12-C		CQA page 37 Steel 11SMnPb37		QOB page 37 Brass CW614N-M		CQF page 38 Steel 11SMnPb37		QBF page 39 Bronze CuSn12-C	
										
THREAD	RH	LH	RH	LH	RH	LH	RH	LH	RH	LH
Tr 10 x 2			■	■						
Tr 10 x 3					■	■				
Tr 12 x 3			■	■	■	■	■	■		
Tr 14 x 3			■	■						
Tr 14 x 4			■	■	■	■	■	■		
Tr 16 x 4			■	■	■	■	■	■	■	■
Tr 18 x 4			■	■	■	■	■	■		
Tr 20 x 4	■	■	■	■	■	■	■	■	■	■
Tr 22 x 5										
Tr 24 x 5										
Tr 25 x 3										
Tr 25 x 5	■	■	■	■	■	■	■	■	■	■
Tr 26 x 5										
Tr 28 x 5										
Tr 30 x 3	■	■								
Tr 30 x 4	■	■								
Tr 30 x 5	■	■								
Tr 30 x 6	■	■	■	■	■	■	■	■	■	■
Tr 32 x 6										
Tr 35 x 3	■	■								
Tr 35 x 4	■	■								
Tr 35 x 5	■	■								
Tr 35 x 6	■	■	■	■	■	■	■	■		
Tr 35 x 8										
Tr 36 x 6			■	■	■	■				
Tr 40 x 3	■	■								
Tr 40 x 4	■	■								
Tr 40 x 5	■	■								
Tr 40 x 6	■	■								
Tr 40 x 7	■	■	■	■	■	■	■	■	■	■
Tr 40 x 8										
Tr 40 x 10	■									
Tr 44 x 7										
Tr 45 x 8										
Tr 50 x 3	■	■								
Tr 50 x 4	■	■								
Tr 50 x 5	■	■								
Tr 50 x 6	■	■								
Tr 50 x 8	■	■	■	■			■	■		
Tr 50 x 10	■									
Tr 55 x 9										
Tr 60 x 6	■									
Tr 60 x 7	■									
Tr 60 x 9	■		■	■			■	■		
Tr 70 x 10										
Tr 80 x 10										
Tr 90 x 12										
Tr 95 x 16										
Tr 100 x 12										
Tr 100 x 16										
Tr 120 x 14										
Tr 120 x 16										
Tr 140 x 14										





■ = Goods in stock

TRAPEZOIDAL NUTS

Single start	FTN page 40 Bronzo CuSn5Zn5Pb5-C		FXN page 41 Bronzo CuSn12-C		FMT page 42 Bronzo CuSn12-C		HDL page 43 Bronzo CuSn12-C		CBC page 44 Bronzo CuSn12-C	
										
THREAD	RH	LH	RH	LH	RH	LH	RH	LH	RH	LH
Tr 10 x 2										
Tr 10 x 3	■	■	■	■	■				■	■
Tr 12 x 3	■	■	■	■	■	■			■	■
Tr 14 x 3										
Tr 14 x 4	■	■	■	■	■	■	■	■	■	■
Tr 16 x 4	■	■	■	■	■	■	■	■	■	■
Tr 18 x 4	■	■	■	■	■	■	■	■	■	■
Tr 20 x 4	■	■	■	■	■	■	■	■	■	■
Tr 22 x 5	■	■	■	■	■	■	■	■		
Tr 24 x 5			■	■						
Tr 25 x 3										
Tr 25 x 5	■	■	■	■	■	■	■	■	■	■
Tr 26 x 5			■	■						
Tr 28 x 5	■	■	■	■	■	■	■	■	■	■
Tr 30 x 3	■	■					■	■		
Tr 30 x 4	■	■								
Tr 30 x 5	■	■								
Tr 30 x 6	■	■	■	■	■	■	■	■	■	■
Tr 32 x 6			■	■			■	■		
Tr 35 x 3	■	■								
Tr 35 x 4	■	■								
Tr 35 x 5	■	■								
Tr 35 x 6	■	■	■	■	■	■	■	■	■	■
Tr 35 x 8	■									
Tr 36 x 6			■	■	■	■			■	■
Tr 40 x 3	■	■								
Tr 40 x 4	■	■					■			
Tr 40 x 5	■	■								
Tr 40 x 6	■	■								
Tr 40 x 7	■	■	■	■	■	■	■	■	■	■
Tr 40 x 8	■									
Tr 40 x 10							■			
Tr 44 x 7			■	■						
Tr 45 x 8	■	■	■	■	■	■			■	■
Tr 50 x 3	■	■								
Tr 50 x 4	■	■								
Tr 50 x 5	■	■								
Tr 50 x 6	■	■					■			
Tr 50 x 8	■	■	■	■	■	■	■	■	■	■
Tr 50 x 10							■			
Tr 55 x 9	■		■		■				■	
Tr 60 x 6	■	■								
Tr 60 x 7	■	■								
Tr 60 x 9	■	■	■	■	■	■	■	■	■	■
Tr 70 x 10									■	■
Tr 80 x 10									■	■
Tr 90 x 12										
Tr 95 x 16										
Tr 100 x 12										
Tr 100 x 16										
Tr 120 x 14										
Tr 120 x 16										
Tr 140 x 14										







■ = Goods in stock

SINGLE START

Single start	FFR page 45 Bronze CuSn5Zn5Pb5-C		HAL page 48 Alluminium Bronze CuAl11Fe6Ni6-C		MES page 49 Steel 11SMnPb37		FCS page 50 Plastic PA6 + MoS2 + self lubricating		MPH page 51 Plastic PA6 + MoS2	
										
THREAD	RH	LH	RH	LH	RH	LH	RH	LH	RH	LH
Tr 10 x 2	■	■			■	■				
Tr 10 x 3					■	■				
Tr 12 x 3	■	■			■	■	■	■	■	■
Tr 14 x 3	■	■			■	■				
Tr 14 x 4					■	■				
Tr 16 x 4	■	■			■	■	■	■	■	■
Tr 18 x 4	■	■			■	■				
Tr 20 x 4	■	■			■	■	■	■	■	■
Tr 22 x 5	■	■			■	■				
Tr 24 x 5	■	■			■	■				
Tr 25 x 3										
Tr 25 x 5							■	■	■	■
Tr 26 x 5	■	■			■	■				
Tr 28 x 5	■	■			■	■	■	■	■	■
Tr 30 x 3										
Tr 30 x 4										
Tr 30 x 5										
Tr 30 x 6	■	■	■	■	■	■	■	■	■	■
Tr 32 x 6	■	■			■	■				
Tr 35 x 3										
Tr 35 x 4										
Tr 35 x 5										
Tr 35 x 6			■				■	■	■	■
Tr 35 x 8										
Tr 36 x 6	■	■			■	■				
Tr 40 x 3										
Tr 40 x 4										
Tr 40 x 5										
Tr 40 x 6										
Tr 40 x 7	■	■	■	■	■	■	■	■	■	■
Tr 40 x 8										
Tr 40 x 10			■				■			
Tr 44 x 7	■	■			■	■				
Tr 45 x 8										
Tr 50 x 3										
Tr 50 x 4										
Tr 50 x 5										
Tr 50 x 6										
Tr 50 x 8	■	■	■	■	■	■	■	■	■	■
Tr 50 x 10			■							
Tr 55 x 9										
Tr 60 x 6										
Tr 60 x 7										
Tr 60 x 9	■	■	■		■	■				
Tr 70 x 10	■	■			■	■				
Tr 80 x 10										
Tr 90 x 12										
Tr 95 x 16										
Tr 100 x 12										
Tr 100 x 16										
Tr 120 x 14										
Tr 120 x 16										
Tr 140 x 14										





■ = Goods in stock

TRAPEZOIDAL NUTS

Multiple start	MLF page 33 Steel 11SMnPb37		MZP page 33 Steel 11SMnPb37		HSN page 34 Bronze CuSn5Zn5Pb5-C		HBD page 34 Bronze CuSn7Zn4Pb7-C		FXN page 41 Bronze CuSn12-C		FMT page 42 Bronze CuSn12-C	
												
THREAD	RH	LH	RH	LH	RH	LH	RH	LH	RH	LH	RH	LH
Tr 10 x 4 (P2)												
Tr 12 x 6 (P3)	■		■				■		■		■	
Tr 14 x 6 (P3)												
Tr 16 x 8 (P4)	■				■				■		■	
Tr 18 x 8 (P4)												
Tr 20 x 8 (P4)	■				■				■		■	
Tr 20 x 20 (P5)									■			
Tr 22 x 10 (P5)												
Tr 24 x 10 (P5)												
Tr 25 x 10 (P5)	■				■				■		■	
Tr 25 x 25 (P5)									■			
Tr 26 x 10 (P5)												
Tr 28 x 10 (P5)	■				■				■			
Tr 30 x 12 (P6)	■				■				■		■	
Tr 30 x 30 (P5)									■			
Tr 32 x 12 (P6)												
Tr 36 x 12 (P6)												
Tr 40 x 14 (P7)	■				■		■		■		■	
Tr 40 x 40 (P8)									■			

■ = Goods in stock.

MULTIPLE START

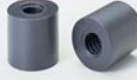
Multiple start	HDL page 43 Bronze CuSn12-C		FFR page 45 Bronze CuSn5Zn5Pb5-C		FHD page 46 Bronze CuSn12-C		CDF page 47 Bronze CuSn12-C		FCS page 50 Plastic PA6 + MoS2+ self lubricating		MPH page 51 Plastic PA6 + MoS2	
												
THREAD	RH	LH	RH	LH	RH	LH	RH	LH	RH	LH	RH	LH
Tr 10 x 4 (P2)			■									
Tr 12 x 6 (P3)			■									
Tr 14 x 6 (P3)			■									
Tr 16 x 8 (P4)	■		■									
Tr 18 x 8 (P4)			■									
Tr 20 x 8 (P4)	■		■						■			
Tr 20 x 20 (P5)												
Tr 22 x 10 (P5)			■									
Tr 24 x 10 (P5)			■									
Tr 25 x 10 (P5)	■						■					
Tr 25 x 25 (P5)	■				■		■					
Tr 26 x 10 (P5)												
Tr 28 x 10 (P5)	■		■				■		■		■	
Tr 30 x 12 (P6)	■		■									
Tr 30 x 30 (P5)												
Tr 32 x 12 (P6)			■									
Tr 36 x 12 (P6)			■									
Tr 40 x 14 (P7)	■		■									
Tr 40 x 40 (P8)					■							

■ = Goods in stock.

Features of CONTI Trapezoidal Screws and Nuts

CONTI trapezoidal screws are precision rolled. Continuous search for improvement and many years of CONTI experience in the development of the cold plastic deformation process which characterizes rolling allow us to offer our customers trapezoidal screws with excellent features.

Materials

Steel used in trapezoidal screws:

EN 10084 C15E - 1.1141	carbon steel
EN 10083-2 1C45 - 1.0503	carbon steel
Inox A2 - AISI 304 -1.4301	stainless steel
Inox A4 - AISI 316 - 1.4401	stainless steel

Surface hardness after rolling

App. 160/180 HB
App. 250 HB
App. 260 HB
App. 280 HB

C45 and A2 stainless steel were chosen because in addition to their natural qualities as good construction materials, after rolling they give very good surface hardness and finish on the thread sides. A4 stainless steel also has excellent corrosion resistance. C15 is an excellent quality-price compromise.

Roughness is less than 1 μm Ra for all.

These two features are decisive factors for qualitative appraisal of trapezoidal screws because they give very small friction coefficients, much lower than those obtainable with machined screws where other conditions such as speed, load and lubrication are equal.

Our trapezoidal screws coupled with bronze nuts give the opportunity to realize translation systems whose efficiency, flowability and quietness are much lower comparing to a coupling with machined screws.

Because of the low friction coefficient the amount of heat generated during movement is limited with resulting smaller nut heating. Nut life is also increased. We make nuts with 10 kinds of material to better meet the various requirements.

Steel used in nuts:

EN 10277-3 11SMnPb37 – 1.0737	steel with sulphur, manganese and lead
EN 10277-3 11SMn30 – 1.0715	steel with sulphur and manganese
INOX A1- AISI 303 – 1.4305	stainless steel

Brass used in nuts:

EN 12164 CW614N-M	brass
-------------------	-------

Bronze used in nuts:

EN 1982 CuSn5Zn5Pb5-C – CC491K	tin bronze with zinc and lead	60-70 HB
EN 1982 CuSn7Zn4Pb7-C – CC493K	tin bronze with zinc and lead	65-75 HB
EN 1982 CuSn12-C – CC483K	tin bronze	80-100 HB
EN 1982 CuAl11Fe6Ni6-C – CC483K	aluminium bronze	160-220 HB

Plastic used in nuts:

PA 6 + Mo S2 DIN 7728	plastic
PA 6 + Mo S2 DIN 7728 + additives	self-lubricating plastic

The nuts we make with length 3xTr: HDL, BIG and HAL deserve special attention.

These bronze nuts, thanks to their considerable length, distribute the load over a larger number of holding threads and thus limit surface contact pressure between screw and nut. This is decisive for long nut life.

By using the 3xTr long nuts compared with bronze nuts with conventional length (approximately 1.5xTr or 2xTr), higher loads can be born for equal traversing speed.

In particular, with HAL aluminium bronze nuts very high loads can be born and it is recommended to apply continuous steady lubrication. HAL nuts have to be coupled with screws in C45 or in stainless steel A2 or A4; C15 screws are not recommended.

Where it is not desired to lubricate trapezoidal screws, self-lubricating plastic nuts are recommended.

It is not possible to couple plastic nuts with screws made by machining.

Positioning Accuracy

To better meet the requirements of customers using trapezoidal screws as positioning system we produce screws with lead accuracy according to the following table

Screw type	Lead Accuracy	Pitch error
KTS	100 (200 *)	+/- 0.100 mm every 300 mm of thread
KUE	100 (200 *)	+/- 0.100 mm every 300 mm of thread
KKA	50	+/- 0.050 mm every 300 mm of thread
KSR	500	+/- 0.500 mm every 300 mm of thread
KQX	200	+/- 0.200 mm every 300 mm of thread
KEQ	200	+/- 0.200 mm every 300 mm of thread
KRP	200	+/- 0.200 mm every 300 mm of thread
KRE	200	+/- 0.200 mm every 300 mm of thread
KAM	200	+/- 0.200 mm every 300 mm of thread
KAF	200	+/- 0.200 mm every 300 mm of thread

* Class 200 for diameters bigger than 80x10.

Straightness

CONTI screws are produced with controlled straightness.

Screw straightness is appraised by measuring the variation of the deflection “ f ” when the screw is supported at the ends on two constraints and slightly rotated.

For example, the screw KKA Tr 30 A (threading Tr 30 x 6 with 1 start) has straightness of 0.3 on 3000 mm. This means that a screw Tr 30x6 3000 mm long resting on two constraints at the ends and rotated slightly displays a camber variation “ Δf ” less than 0.3 mm at all points of the screw.

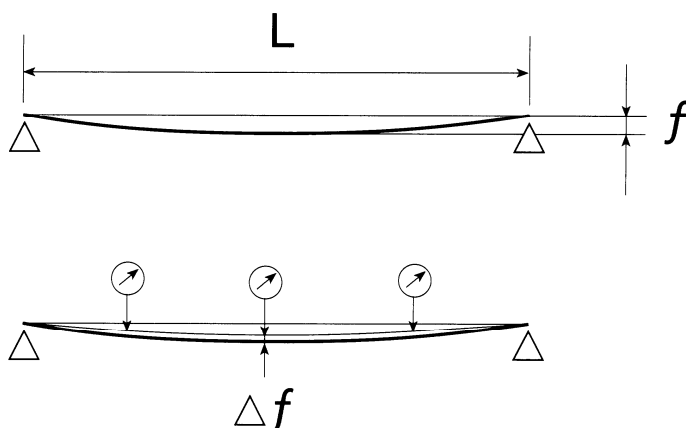

f = screw weight camber

for screws Tr 30x6 with $L = 3000$ mm

Δf maximum: 0.3 mm

Good screw straightness gives operation with load always centred on the axis, hence uniform distribution of surface contact pressure between screw and nut with resulting smooth running, and regular rotation and translation.

Trapezoidal screws type KTS – Steel C45 1.0503

Stock no. for screw RIGHT	Stock no. for screw LEFT	Diameter x lead	Thread starts	Lead accuracy µm /300 mm	Straightness mm / mm	Weight kg/mt
■ KTS 10 T R ...	■ KTS 10 T L ...	Tr 10x2	1	100	0,5 / 1000	0,48
■ KTS 10 A R ...	■ KTS 10 A L ...	Tr 10x3	1	100	0,5 / 1000	0,42
■ KTS 12 A R ...	■ KTS 12 A L ...	Tr 12x3	1	100	0,5 / 1000	0,65
■ KTS 14 R R ...	■ KTS 14 R L ...	Tr 14x3	1	100	0,5 / 1000	0,93
■ KTS 14 A R ...	■ KTS 14 A L ...	Tr 14x4	1	100	0,5 / 1000	0,86
■ KTS 16 A R ...	■ KTS 16 A L ...	Tr 16x4	1	100	0,5 / 1000	1,17
■ KTS 18 A R ...	■ KTS 18 A L ...	Tr 18x4	1	100	0,5 / 1000	1,53
■ KTS 20 A R ...	■ KTS 20 A L ...	Tr 20x4	1	100	0,4 / 2000	1,94
■ KTS 22 A R ...	■ KTS 22 A L ...	Tr 22x5	1	100	0,4 / 2000	2,29
■ KTS 24 A R ...	■ KTS 24 A L ...	Tr 24x5	1	100	0,4 / 2000	2,78
■ KTS 25 R R ...	□ KTS 25 R L ...	Tr 25x3	1	100	0,3 / 2000	3,30
■ KTS 25 A R ...	■ KTS 25 A L ...	Tr 25x5	1	100	0,3 / 2000	3,05
■ KTS 26 A R ...	■ KTS 26 A L ...	Tr 26x5	1	100	0,3 / 2000	3,33
■ KTS 28 A R ...	■ KTS 28 A L ...	Tr 28x5	1	100	0,3 / 2000	3,92
□ KTS 30 P R ...	□ KTS 30 P L ...	Tr 30x5	1	100	0,3 / 3000	4,57
■ KTS 30 A R ...	■ KTS 30 A L ...	Tr 30x6	1	100	0,3 / 3000	4,38
■ KTS 32 A R ...	■ KTS 32 A L ...	Tr 32x6	1	100	0,3 / 3000	5,06
□ KTS 35 P R ...	□ KTS 35 P L ...	Tr 35x5	1	100	0,3 / 3000	6,40
■ KTS 35 A R ...	■ KTS 35 A L ...	Tr 35x6	1	100	0,3 / 3000	6,16
■ KTS 35 M R ...	□ KTS 35 M L ...	Tr 35x8	1	100	0,3 / 3000	5,85
■ KTS 36 A R ...	■ KTS 36 A L ...	Tr 36x6	1	100	0,3 / 3000	6,56
□ KTS 40 P R ...	□ KTS 40 P L ...	Tr 40x5	1	100	0,3 / 3000	8,51
■ KTS 40 O R ...	■ KTS 40 O L ...	Tr 40x6	1	100	0,3 / 3000	8,26
■ KTS 40 A R ...	■ KTS 40 A L ...	Tr 40x7	1	100	0,3 / 3000	8,03
■ KTS 40 M R ...	□ KTS 40 M L ...	Tr 40x8	1	100	0,3 / 3000	7,90
■ KTS 40 I R ...	□ KTS 40 I L ...	Tr 40x10	1	100	0,3 / 3000	7,49
■ KTS 44 A R ...	■ KTS 44 A L ...	Tr 44x7	1	100	0,3 / 3000	9,90
■ KTS 45 A R ...	■ KTS 45 A L ...	Tr 45x8	1	100	0,3 / 3000	10,23
□ KTS 50 P R ...	□ KTS 50 P L ...	Tr 50x5	1	100	0,3 / 3000	13,70
□ KTS 50 O R ...	□ KTS 50 O L ...	Tr 50x6	1	100	0,3 / 3000	13,35
■ KTS 50 A R ...	■ KTS 50 A L ...	Tr 50x8	1	100	0,3 / 3000	12,90
■ KTS 50 I R ...	□ KTS 50 I L ...	Tr 50x10	1	100	0,3 / 3000	12,37
■ KTS 55 A R ...	□ KTS 55 A L ...	Tr 55x9	1	100	0,3 / 3000	15,51
□ KTS 60 O R ...	□ KTS 60 O L ...	Tr 60x6	1	100	0,3 / 3000	19,67
□ KTS 60 N R ...	□ KTS 60 N L ...	Tr 60x7	1	100	0,3 / 3000	19,36
■ KTS 60 A R ...	■ KTS 60 A L ...	Tr 60x9	1	100	0,3 / 3000	18,74
■ KTS 70 A R ...	■ KTS 70 A L ...	Tr 70x10	1	100	0,3 / 3000	25,80
■ KTS 80 A R ...	■ KTS 80 A L ...	Tr 80x10	1	100	0,3 / 3000	34,39
■ KTS 90 A R ...	□ KTS 90 A L ...	Tr 90x12	1	200	0,5 / 300	43,07
■ KTS 95 W R ...	□ KTS 95 W L ...	Tr 95x16	1	200	1 / 300	45,90
■ KTS A0 A R ...	□ KTS A0 A L ...	Tr 100x12	1	200	1 / 300	53,99
■ KTS A0 W R ...	□ KTS A0 W L ...	Tr 100x16	1	200	1 / 300	51,37
■ KTS C0 A R ...	□ KTS C0 A L ...	Tr 120x14	1	200	1 / 300	77,72
■ KTS C0 W R ...	□ KTS C0 W L ...	Tr 120x16	1	200	1 / 300	76,34
■ KTS E0 A R ...	□ KTS E0 A L ...	Tr 140x14	1	200	1 / 300	107,87

■ = Goods in stock.

□ = Goods available upon request only.

Trapezoidal screws type KUE – Steel C45 1.0503

Stock no. for screw RIGHT	Stock no. for screw LEFT	Diameter x lead	Thread starts	Lead accuracy µm /300 mm	Straightness mm / mm	Weight kg/mt
■ KUE 10 T R ...	■ KUE 10 T L ...	Tr 10x2	1	100	0,5 / 300	0,48
■ KUE 10 A R ...	■ KUE 10 A L ...	Tr 10x3	1	100	0,5 / 300	0,42
■ KUE 12 A R ...	■ KUE 12 A L ...	Tr 12x3	1	100	0,5 / 300	0,65
■ KUE 14 R R ...	■ KUE 14 R L ...	Tr 14x3	1	100	0,5 / 300	0,93
■ KUE 14 A R ...	■ KUE 14 A L ...	Tr 14x4	1	100	0,5 / 300	0,86
■ KUE 16 A R ...	■ KUE 16 A L ...	Tr 16x4	1	100	0,5 / 300	1,17
■ KUE 18 A R ...	■ KUE 18 A L ...	Tr 18x4	1	100	0,5 / 300	1,53
■ KUE 20 A R ...	■ KUE 20 A L ...	Tr 20x4	1	100	0,5 / 300	1,94
■ KUE 22 A R ...	■ KUE 22 A L ...	Tr 22x5	1	100	0,2 / 300	2,29
■ KUE 24 A R ...	■ KUE 24 A L ...	Tr 24x5	1	100	0,2 / 300	2,78
■ KUE 25 R R ...	□ KUE 25 R L ...	Tr 25x3	1	100	0,2 / 300	3,30
■ KUE 25 A R ...	■ KUE 25 A L ...	Tr 25x5	1	100	0,2 / 300	3,05
■ KUE 26 A R ...	■ KUE 26 A L ...	Tr 26x5	1	100	0,2 / 300	3,33
■ KUE 28 A R ...	■ KUE 28 A L ...	Tr 28x5	1	100	0,2 / 300	3,92
□ KUE 30 P R ...	□ KUE 30 P L ...	Tr 30x5	1	100	0,2 / 300	4,57
■ KUE 30 A R ...	■ KUE 30 A L ...	Tr 30x6	1	100	0,2 / 300	4,38
■ KUE 32 A R ...	■ KUE 32 A L ...	Tr 32x6	1	100	0,2 / 300	5,06
□ KUE 35 P R ...	□ KUE 35 P L ...	Tr 35x5	1	100	0,2 / 300	6,40
■ KUE 35 A R ...	■ KUE 35 A L ...	Tr 35x6	1	100	0,2 / 300	6,16
■ KUE 35 M R ...	□ KUE 35 M L ...	Tr 35x8	1	100	0,2 / 300	5,85
■ KUE 36 A R ...	■ KUE 36 A L ...	Tr 36x6	1	100	0,2 / 300	6,56
□ KUE 40 P R ...	□ KUE 40 P L ...	Tr 40x5	1	100	0,2 / 300	8,51
■ KUE 40 O R ...	■ KUE 40 O L ...	Tr 40x6	1	100	0,2 / 300	8,26
■ KUE 40 A R ...	■ KUE 40 A L ...	Tr 40x7	1	100	0,2 / 300	8,03
■ KUE 40 M R ...	□ KUE 40 M L ...	Tr 40x8	1	100	0,2 / 300	7,90
■ KUE 40 I R ...	□ KUE 40 I L ...	Tr 40x10	1	100	0,2 / 300	7,49
■ KUE 44 A R ...	■ KUE 44 A L ...	Tr 44x7	1	100	0,2 / 300	9,90
■ KUE 45 A R ...	■ KUE 45 A L ...	Tr 45x8	1	100	0,2 / 300	10,23
□ KUE 50 P R ...	□ KUE 50 P L ...	Tr 50x5	1	100	0,2 / 300	13,70
□ KUE 50 O R ...	□ KUE 50 O L ...	Tr 50x6	1	100	0,2 / 300	13,35
■ KUE 50 A R ...	■ KUE 50 A L ...	Tr 50x8	1	100	0,2 / 300	12,90
■ KUE 50 I R ...	□ KUE 50 I L ...	Tr 50x10	1	100	0,2 / 300	12,37
■ KUE 55 A R ...	□ KUE 55 A L ...	Tr 55x9	1	100	0,2 / 300	15,51
□ KUE 60 O R ...	□ KUE 60 O L ...	Tr 60x6	1	100	0,2 / 300	19,67
□ KUE 60 N R ...	□ KUE 60 N L ...	Tr 60x7	1	100	0,2 / 300	19,36
■ KUE 60 A R ...	■ KUE 60 A L ...	Tr 60x9	1	100	0,2 / 300	18,74
■ KUE 70 A R ...	■ KUE 70 A L ...	Tr 70x10	1	100	0,4 / 300	25,80
■ KUE 80 A R ...	■ KUE 80 A L ...	Tr 80x10	1	100	0,4 / 300	34,39
■ KUE 90 A R ...	□ KUE 90 A L ...	Tr 90x12	1	200	0,5 / 300	43,07
■ KUE 95 W R ...	□ KUE 95 W L ...	Tr 95x16	1	200	1 / 300	45,90
■ KUE A0 A R ...	□ KUE A0 A L ...	Tr 100x12	1	200	1 / 300	53,99
■ KUE A0 W R ...	□ KUE A0 W L ...	Tr 100x16	1	200	1 / 300	51,37
■ KUE C0 A R ...	□ KUE C0 A L ...	Tr 120x14	1	200	1 / 300	77,72
■ KUE C0 W R ...	□ KUE C0 W L ...	Tr 120x16	1	200	1 / 300	76,34
■ KUE E0 A R ...	□ KUE E0 A L ...	Tr 140x14	1	200	1 / 300	107,87

■ = Goods in stock.

□ = Goods available upon request only.

Trapezoidal screws type KKA – Steel C45 1.0503

Stock no. for screw RIGHT	Stock no. for screw LEFT	Diameter x lead	Thread starts	Lead accuracy µm /300 mm	Straightness mm / mm	Weight kg/mt
□ KKA 10 T R ...	□ KKA 10 T L ...	Tr 10x2	1	50	0,5 / 1000	0,48
□ KKA 10 A R ...	□ KKA 10 A L ...	Tr 10x3	1	50	0,5 / 1000	0,42
□ KKA 12 A R ...	□ KKA 12 A L ...	Tr 12x3	1	50	0,5 / 1000	0,65
□ KKA 14 R R ...	□ KKA 14 R L ...	Tr 14x3	1	50	0,5 / 1000	0,93
□ KKA 14 A R ...	□ KKA 14 A L ...	Tr 14x4	1	50	0,5 / 1000	0,86
■ KKA 16 A R ...	□ KKA 16 A L ...	Tr 16x4	1	50	0,5 / 1000	1,17
□ KKA 18 A R ...	□ KKA 18 A L ...	Tr 18x4	1	50	0,5 / 1000	1,53
■ KKA 20 A R ...	□ KKA 20 A L ...	Tr 20x4	1	50	0,4 / 2000	1,94
□ KKA 22 A R ...	□ KKA 22 A L ...	Tr 22x5	1	50	0,4 / 2000	2,29
□ KKA 24 A R ...	□ KKA 24 A L ...	Tr 24x5	1	50	0,4 / 2000	2,78
■ KKA 25 A R ...	□ KKA 25 A L ...	Tr 25x5	1	50	0,3 / 2000	3,05
□ KKA 26 A R ...	□ KKA 26 A L ...	Tr 26x5	1	50	0,3 / 2000	3,33
■ KKA 28 A R ...	□ KKA 28 A L ...	Tr 28x5	1	50	0,3 / 2000	3,92
□ KKA 30 P R ...	□ KKA 30 P L ...	Tr 30x5	1	50	0,3 / 3000	4,57
■ KKA 30 A R ...	□ KKA 30 A L ...	Tr 30x6	1	50	0,3 / 3000	4,38
□ KKA 32 A R ...	□ KKA 32 A L ...	Tr 32x6	1	50	0,3 / 3000	5,06
□ KKA 35 P R ...	□ KKA 35 P L ...	Tr 35x5	1	50	0,3 / 3000	6,40
■ KKA 35 A R ...	□ KKA 35 A L ...	Tr 35x6	1	50	0,3 / 3000	6,16
□ KKA 35 M R ...	□ KKA 35 M L ...	Tr 35x8	1	50	0,3 / 3000	5,85
□ KKA 36 A R ...	□ KKA 36 A L ...	Tr 36x6	1	50	0,3 / 3000	6,56
□ KKA 40 P R ...	□ KKA 40 P L ...	Tr 40x5	1	50	0,3 / 3000	8,51
□ KKA 40 O R ...	□ KKA 40 O L ...	Tr 40x6	1	50	0,3 / 3000	8,26
■ KKA 40 A R ...	□ KKA 40 A L ...	Tr 40x7	1	50	0,3 / 3000	8,03
□ KKA 40 M R ...	□ KKA 40 M L ...	Tr 40x8	1	50	0,3 / 3000	7,90
□ KKA 40 I R ...	□ KKA 40 I L ...	Tr 40x10	1	50	0,3 / 3000	7,49
□ KKA 44 A R ...	□ KKA 44 A L ...	Tr 44x7	1	50	0,3 / 3000	9,90
□ KKA 45 A R ...	□ KKA 45 A L ...	Tr 45x8	1	50	0,3 / 3000	10,23
□ KKA 50 P R ...	□ KKA 50 P L ...	Tr 50x5	1	50	0,3 / 3000	13,70
□ KKA 50 O R ...	□ KKA 50 O L ...	Tr 50x6	1	50	0,3 / 3000	13,35
■ KKA 50 A R ...	□ KKA 50 A L ...	Tr 50x8	1	50	0,3 / 3000	12,90
□ KKA 50 I R ...	□ KKA 50 I L ...	Tr 50x10	1	50	0,3 / 3000	12,37
□ KKA 55 A R ...	□ KKA 55 A L ...	Tr 55x9	1	50	0,3 / 3000	15,51
□ KKA 60 O R ...	□ KKA 60 O L ...	Tr 60x6	1	50	0,3 / 3000	19,67
□ KKA 60 N R ...	□ KKA 60 N L ...	Tr 60x7	1	50	0,3 / 3000	19,36
□ KKA 60 A R ...	□ KKA 60 A L ...	Tr 60x9	1	50	0,3 / 3000	18,74
□ KKA 70 A R ...	□ KKA 70 A L ...	Tr 70x10	1	50	0,3 / 3000	25,80
□ KKA 80 A R ...	□ KKA 80 A L ...	Tr 80x10	1	50	0,3 / 3000	34,39

■ = Goods in stock.

□ = Goods available upon request only.

Trapezoidal screws type KSR – Steel C45 1.0503

Stock no. for screw RIGHT	Stock no. for screw LEFT	Diameter x lead	Thread starts	Lead accuracy µm /300 mm	Straightness mm / mm	Weight kg/mt
<input type="checkbox"/> KSR 10 T R ...	<input type="checkbox"/> KSR 10 T L ...	Tr 10x2	1	500	--	0,48
<input type="checkbox"/> KSR 10 A R ...	<input type="checkbox"/> KSR 10 A L ...	Tr 10x3	1	500	--	0,42
<input type="checkbox"/> KSR 12 A R ...	<input type="checkbox"/> KSR 12 A L ...	Tr 12x3	1	500	--	0,65
<input type="checkbox"/> KSR 14 R R ...	<input type="checkbox"/> KSR 14 R L ...	Tr 14x3	1	500	--	0,93
<input type="checkbox"/> KSR 14 A R ...	<input type="checkbox"/> KSR 14 A L ...	Tr 14x4	1	500	--	0,86
<input type="checkbox"/> KSR 16 A R ...	<input type="checkbox"/> KSR 16 A L ...	Tr 16x4	1	500	--	1,17
<input type="checkbox"/> KSR 18 A R ...	<input type="checkbox"/> KSR 18 A L ...	Tr 18x4	1	500	--	1,53
<input type="checkbox"/> KSR 20 A R ...	<input type="checkbox"/> KSR 20 A L ...	Tr 20x4	1	500	--	1,94
<input type="checkbox"/> KSR 22 A R ...	<input type="checkbox"/> KSR 22 A L ...	Tr 22x5	1	500	--	2,29
<input type="checkbox"/> KSR 24 A R ...	<input type="checkbox"/> KSR 24 A L ...	Tr 24x5	1	500	--	2,78
<input type="checkbox"/> KSR 25 R R ...	<input type="checkbox"/> KSR 25 R L ...	Tr 25x3	1	500	--	3,30
<input type="checkbox"/> KSR 25 A R ...	<input type="checkbox"/> KSR 25 A L ...	Tr 25x5	1	500	--	3,05
<input type="checkbox"/> KSR 26 A R ...	<input type="checkbox"/> KSR 26 A L ...	Tr 26x5	1	500	--	3,33
<input type="checkbox"/> KSR 28 A R ...	<input type="checkbox"/> KSR 28 A L ...	Tr 28x5	1	500	--	3,92
<input type="checkbox"/> KSR 30 R R ...	<input type="checkbox"/> KSR 30 R L ...	Tr 30x3	1	500	--	4,57
<input type="checkbox"/> KSR 30 Q R ...	<input type="checkbox"/> KSR 30 Q L ...	Tr 30x4	1	500	--	4,57
<input type="checkbox"/> KSR 30 P R ...	<input type="checkbox"/> KSR 30 P L ...	Tr 30x5	1	500	--	4,57
<input type="checkbox"/> KSR 30 A R ...	<input type="checkbox"/> KSR 30 A L ...	Tr 30x6	1	500	--	4,38
<input type="checkbox"/> KSR 32 A R ...	<input type="checkbox"/> KSR 32 A L ...	Tr 32x6	1	500	--	5,06
<input type="checkbox"/> KSR 35 R R ...	<input type="checkbox"/> KSR 35 R L ...	Tr 35x3	1	500	--	6,77
<input type="checkbox"/> KSR 35 Q R ...	<input type="checkbox"/> KSR 35 Q L ...	Tr 35x4	1	500	--	6,57
<input type="checkbox"/> KSR 35 P R ...	<input type="checkbox"/> KSR 35 P L ...	Tr 35x5	1	500	--	6,40
<input type="checkbox"/> KSR 35 A R ...	<input type="checkbox"/> KSR 35 A L ...	Tr 35x6	1	500	--	6,16
<input type="checkbox"/> KSR 35 M R ...	<input type="checkbox"/> KSR 35 M L ...	Tr 35x8	1	500	--	5,85
<input type="checkbox"/> KSR 36 A R ...	<input type="checkbox"/> KSR 36 A L ...	Tr 36x6	1	500	--	6,56
<input type="checkbox"/> KSR 40 R R ...	<input type="checkbox"/> KSR 40 R L ...	Tr 40x3	1	500	--	8,95
<input type="checkbox"/> KSR 40 Q R ...	<input type="checkbox"/> KSR 40 Q L ...	Tr 40x4	1	500	--	8,71
<input type="checkbox"/> KSR 40 P R ...	<input type="checkbox"/> KSR 40 P L ...	Tr 40x5	1	500	--	8,51
<input type="checkbox"/> KSR 40 O R ...	<input type="checkbox"/> KSR 40 O L ...	Tr 40x6	1	500	--	8,26
<input type="checkbox"/> KSR 40 A R ...	<input type="checkbox"/> KSR 40 A L ...	Tr 40x7	1	500	--	8,03
<input type="checkbox"/> KSR 40 M R ...	<input type="checkbox"/> KSR 40 M L ...	Tr 40x8	1	500	--	7,90
<input type="checkbox"/> KSR 40 I R ...	<input type="checkbox"/> KSR 40 I L ...	Tr 40x10	1	500	--	7,49
<input type="checkbox"/> KSR 44 A R ...	<input type="checkbox"/> KSR 44 A L ...	Tr 44x7	1	500	--	9,90
<input type="checkbox"/> KSR 45 A R ...	<input type="checkbox"/> KSR 45 A L ...	Tr 45x8	1	500	--	10,23
<input type="checkbox"/> KSR 50 R R ...	<input type="checkbox"/> KSR 50 R L ...	Tr 50x3	1	500	--	14,26
<input type="checkbox"/> KSR 50 Q R ...	<input type="checkbox"/> KSR 50 Q L ...	Tr 50x4	1	500	--	13,96
<input type="checkbox"/> KSR 50 P R ...	<input type="checkbox"/> KSR 50 P L ...	Tr 50x5	1	500	--	13,70
<input type="checkbox"/> KSR 50 O R ...	<input type="checkbox"/> KSR 50 O L ...	Tr 50x6	1	500	--	13,35
<input type="checkbox"/> KSR 50 A R ...	<input type="checkbox"/> KSR 50 A L ...	Tr 50x8	1	500	--	12,90
<input type="checkbox"/> KSR 50 I R ...	<input type="checkbox"/> KSR 50 I L ...	Tr 50x10	1	500	--	12,37
<input type="checkbox"/> KSR 55 A R ...	<input type="checkbox"/> KSR 55 A L ...	Tr 55x9	1	500	--	15,51
<input type="checkbox"/> KSR 60 O R ...	<input type="checkbox"/> KSR 60 O L ...	Tr 60x6	1	500	--	19,67
<input type="checkbox"/> KSR 60 N R ...	<input type="checkbox"/> KSR 60 N L ...	Tr 60x7	1	500	--	19,36
<input type="checkbox"/> KSR 60 A R ...	<input type="checkbox"/> KSR 60 A L ...	Tr 60x9	1	500	--	18,74
<input type="checkbox"/> KSR 70 A R ...	<input type="checkbox"/> KSR 70 A L ...	Tr 70x10	1	500	--	25,80
<input type="checkbox"/> KSR 80 A R ...	<input type="checkbox"/> KSR 80 A L ...	Tr 80x10	1	500	--	34,39

■ = Goods in stock.

□ = Goods available upon request only.

Trapezoidal screws type KQX – Steel C15 1.1141

Stock no. for screw RIGHT	Stock no. for screw LEFT	Diameter x lead	Thread starts	Lead accuracy µm /300 mm	Straightness mm / mm	Weight kg/mt
■ KQX 10 TR ...	□ KQX 10 TL ...	Tr 10x2	1	200	0,7 / 1000	0,48
■ KQX 10 AR ...	■ KQX 10 AL ...	Tr 10x3	1	200	0,7 / 1000	0,42
■ KQX 12 AR ...	■ KQX 12 AL ...	Tr 12x3	1	200	0,7 / 1000	0,65
■ KQX 14 RR ...	□ KQX 14 RL ...	Tr 14x3	1	200	0,7 / 1000	0,93
■ KQX 14 AR ...	■ KQX 14 AL ...	Tr 14x4	1	200	0,7 / 1000	0,86
■ KQX 16 AR ...	■ KQX 16 AL ...	Tr 16x4	1	200	0,7 / 1500	1,17
■ KQX 18 AR ...	■ KQX 18 AL ...	Tr 18x4	1	200	0,7 / 1500	1,53
■ KQX 20 AR ...	■ KQX 20 AL ...	Tr 20x4	1	200	0,6 / 2000	1,94
■ KQX 22 AR ...	■ KQX 22 AL ...	Tr 22x5	1	200	0,6 / 2000	2,29
■ KQX 24 AR ...	■ KQX 24 AL ...	Tr 24x5	1	200	0,4 / 2000	2,78
□ KQX 25 RR ...	□ KQX 25 RL ...	Tr 25x3	1	200	0,4 / 2000	3,30
■ KQX 25 AR ...	■ KQX 25 AL ...	Tr 25x5	1	200	0,4 / 2000	3,05
■ KQX 26 AR ...	■ KQX 26 AL ...	Tr 26x5	1	200	0,4 / 2000	3,33
■ KQX 28 AR ...	■ KQX 28 AL ...	Tr 28x5	1	200	0,4 / 2000	3,92
■ KQX 30 RR *	■ KQX 30 RL *	Tr 30x3	1	200	0,4 / 3000	4,57
■ KQX 30 QR *	■ KQX 30 QL *	Tr 30x4	1	200	0,4 / 3000	4,57
■ KQX 30 PR *	■ KQX 30 PL *	Tr 30x5	1	200	0,4 / 3000	4,57
■ KQX 30 AR ...	■ KQX 30 AL ...	Tr 30x6	1	200	0,4 / 3000	4,38
■ KQX 32 AR ...	■ KQX 32 AL ...	Tr 32x6	1	200	0,4 / 3000	5,06
■ KQX 35 RR *	■ KQX 35 RL *	Tr 35x3	1	200	0,3 / 3000	6,77
■ KQX 35 QR *	■ KQX 35 QL *	Tr 35x4	1	200	0,3 / 3000	6,57
■ KQX 35 PR *	■ KQX 35 PL *	Tr 35x5	1	200	0,3 / 3000	6,40
■ KQX 35 AR ...	■ KQX 35 AL ...	Tr 35x6	1	200	0,3 / 3000	6,16
□ KQX 35 MR ...	□ KQX 35 ML ...	Tr 35x8	1	200	0,3 / 3000	5,85
■ KQX 36 AR ...	■ KQX 36 AL ...	Tr 36x6	1	200	0,3 / 3000	6,56
■ KQX 40 RR *	■ KQX 40 RL *	Tr 40x3	1	200	0,3 / 3000	8,95
■ KQX 40 QR *	■ KQX 40 QL *	Tr 40x4	1	200	0,3 / 3000	8,71
■ KQX 40 PR *	■ KQX 40 PL *	Tr 40x5	1	200	0,3 / 3000	8,51
□ KQX 40 OR *	□ KQX 40 OL *	Tr 40x6	1	200	0,3 / 3000	8,26
■ KQX 40 AR ...	■ KQX 40 AL ...	Tr 40x7	1	200	0,3 / 3000	8,03
□ KQX 40 MR ...	□ KQX 40 ML ...	Tr 40x8	1	200	0,3 / 3000	7,90
□ KQX 40 IR ...	□ KQX 40 IL ...	Tr 40x10	1	200	0,3 / 3000	7,49
■ KQX 44 AR ...	■ KQX 44 AL ...	Tr 44x7	1	200	0,3 / 3000	9,90
■ KQX 45 AR ...	■ KQX 45 AL ...	Tr 45x8	1	200	0,3 / 3000	10,23
■ KQX 50 RR *	■ KQX 50 RL *	Tr 50x3	1	200	0,3 / 3000	14,26
■ KQX 50 QR *	■ KQX 50 QL *	Tr 50x4	1	200	0,3 / 3000	13,96
■ KQX 50 PR *	■ KQX 50 PL *	Tr 50x5	1	200	0,3 / 3000	13,70
■ KQX 50 OR *	■ KQX 50 OL *	Tr 50x6	1	200	0,3 / 3000	13,35
■ KQX 50 AR ...	■ KQX 50 AL ...	Tr 50x8	1	200	0,3 / 3000	12,90
■ KQX 50 IR ...	□ KQX 50 IL ...	Tr 50x10	1	200	0,3 / 3000	12,37
■ KQX 55 AR ...	□ KQX 55 AL ...	Tr 55x9	1	200	0,3 / 3000	15,51
■ KQX 60 OR ...	■ KQX 60 OL ...	Tr 60x6	1	200	0,3 / 3000	19,67
■ KQX 60 NR ...	■ KQX 60 NL ...	Tr 60x7	1	200	0,3 / 3000	19,36
■ KQX 60 AR ...	■ KQX 60 AL ...	Tr 60x9	1	200	0,3 / 3000	18,74
■ KQX 70 AR ...	□ KQX 70 AL ...	Tr 70x10	1	200	0,3 / 3000	25,80
■ KQX 80 AR ...	□ KQX 80 AL ...	Tr 80x10	1	200	0,3 / 3000	34,39

* The screw can be supplied as alternative KCC, obtained by thread whirling, at company Conti's choice.

■ = Goods in stock.

□ = Goods available upon request only.

Trapezoidal screws type KEQ – Steel C15 1.1141

Stock no. for screw RIGHT	Stock no. for screw LEFT	Diameter x lead	Thread starts	Lead accuracy µm /300 mm	Straightness mm / mm	Weight kg/mt
■ KEQ 10 T R ...	□ KEQ 10 T L ...	Tr 10x2	1	200	--	0,48
■ KEQ 10 A R ...	□ KEQ 10 A L ...	Tr 10x3	1	200	--	0,42
■ KEQ 12 A R ...	□ KEQ 12 A L ...	Tr 12x3	1	200	--	0,65
■ KEQ 14 R R ...	□ KEQ 14 R L ...	Tr 14x3	1	200	--	0,93
■ KEQ 14 A R ...	□ KEQ 14 A L ...	Tr 14x4	1	200	--	0,86
■ KEQ 16 A R ...	□ KEQ 16 A L ...	Tr 16x4	1	200	--	1,17
■ KEQ 18 A R ...	□ KEQ 18 A L ...	Tr 18x4	1	200	--	1,53
■ KEQ 20 A R ...	□ KEQ 20 A L ...	Tr 20x4	1	200	--	1,94
■ KEQ 22 A R ...	□ KEQ 22 A L ...	Tr 22x5	1	200	--	2,29
■ KEQ 24 A R ...	□ KEQ 24 A L ...	Tr 24x5	1	200	--	2,78
□ KEQ 25 R R ...	□ KEQ 25 R L ...	Tr 25x3	1	200	--	3,30
□ KEQ 25 A R ...	□ KEQ 25 A L ...	Tr 25x5	1	200	--	3,05
■ KEQ 26 A R ...	□ KEQ 26 A L ...	Tr 26x5	1	200	--	3,33
■ KEQ 28 A R ...	□ KEQ 28 A L ...	Tr 28x5	1	200	--	3,92
□ KEQ 30 R R ...	□ KEQ 30 R L ...	Tr 30x3	1	200	--	4,57
□ KEQ 30 Q R ...	□ KEQ 30 Q L ...	Tr 30x4	1	200	--	4,57
□ KEQ 30 P R ...	□ KEQ 30 P L ...	Tr 30x5	1	200	--	4,57
■ KEQ 30 A R ...	□ KEQ 30 A L ...	Tr 30x6	1	200	--	4,38
■ KEQ 32 A R ...	□ KEQ 32 A L ...	Tr 32x6	1	200	--	5,06
□ KEQ 35 R R ...	□ KEQ 35 R L ...	Tr 35x3	1	200	--	6,77
□ KEQ 35 Q R ...	□ KEQ 35 Q L ...	Tr 35x4	1	200	--	6,57
□ KEQ 35 P R ...	□ KEQ 35 P L ...	Tr 35x5	1	200	--	6,40
□ KEQ 35 A R ...	□ KEQ 35 A L ...	Tr 35x6	1	200	--	6,16
□ KEQ 35 M R ...	□ KEQ 35 M L ...	Tr 35x8	1	200	--	5,85
■ KEQ 36 A R ...	□ KEQ 36 A L ...	Tr 36x6	1	200	--	6,56
□ KEQ 40 R R ...	□ KEQ 40 R L ...	Tr 40x3	1	200	--	8,95
□ KEQ 40 Q R ...	□ KEQ 40 Q L ...	Tr 40x4	1	200	--	8,71
□ KEQ 40 P R ...	□ KEQ 40 P L ...	Tr 40x5	1	200	--	8,51
□ KEQ 40 O R ...	□ KEQ 40 O L ...	Tr 40x6	1	200	--	8,26
■ KEQ 40 A R ...	□ KEQ 40 A L ...	Tr 40x7	1	200	--	8,03
□ KEQ 40 M R ...	□ KEQ 40 M L ...	Tr 40x8	1	200	--	7,90
□ KEQ 40 I R ...	□ KEQ 40 I L ...	Tr 40x10	1	200	--	7,49
■ KEQ 44 A R ...	□ KEQ 44 A L ...	Tr 44x7	1	200	--	9,90
□ KEQ 45 A R ...	□ KEQ 45 A L ...	Tr 45x8	1	200	--	10,23
□ KEQ 50 R R ...	□ KEQ 50 R L ...	Tr 50x3	1	200	--	14,26
□ KEQ 50 Q R ...	□ KEQ 50 Q L ...	Tr 50x4	1	200	--	13,96
□ KEQ 50 P R ...	□ KEQ 50 P L ...	Tr 50x5	1	200	--	13,70
□ KEQ 50 O R ...	□ KEQ 50 O L ...	Tr 50x6	1	200	--	13,35
■ KEQ 50 A R ...	□ KEQ 50 A L ...	Tr 50x8	1	200	--	12,90
□ KEQ 50 I R ...	□ KEQ 50 I L ...	Tr 50x10	1	200	--	12,37
■ KEQ 55 A R ...	□ KEQ 55 A L ...	Tr 55x9	1	200	--	15,51
□ KEQ 60 O R ...	□ KEQ 60 O L ...	Tr 60x6	1	200	--	19,67
□ KEQ 60 N R ...	□ KEQ 60 N L ...	Tr 60x7	1	200	--	19,36
■ KEQ 60 A R ...	□ KEQ 60 A L ...	Tr 60x9	1	200	--	18,74
■ KEQ 70 A R ...	□ KEQ 70 A L ...	Tr 70x10	1	200	--	25,80
■ KEQ 80 A R ...	□ KEQ 80 A L ...	Tr 80x10	1	200	--	34,39

■ = Goods in stock.

□ = Goods available upon request only.

Trapezoidal screws type KRP

A2 stainless steel - AISI 304 1.4301

Stock no. for screw RIGHT	Stock no. for screw LEFT	Diameter x lead	Thread starts	Lead accuracy µm / 300 mm	Straightness mm / mm	Weight kg/mt
□ KRP 10 T R ... □ KRP 10 A R ... ■ KRP 12 A R ...	□ KRP 10 T L ... □ KRP 10 A L ... ■ KRP 12 A L ...	Tr 10x2 Tr 10x3 Tr 12x3	1 1 1	200 200 200	0,7 / 1000 0,7 / 1000 0,7 / 1000	0,48 0,42 0,65
□ KRP 14 R R ... ■ KRP 14 A R ...	□ KRP 14 R L ... ■ KRP 14 A L ...	Tr 14x3 Tr 14x4	1 1	200 200	0,7 / 1000 0,7 / 1000	0,93 0,86
■ KRP 16 A R ... ■ KRP 18 A R ...	■ KRP 16 A L ... ■ KRP 18 A L ...	Tr 16x4 Tr 18x4	1 1	200 200	0,7 / 1500 0,7 / 1500	1,17 1,53
■ KRP 20 A R ... □ KRP 22 A R ...	■ KRP 20 A L ... □ KRP 22 A L ...	Tr 20x4 Tr 22x5	1 1	200 200	0,6 / 2000 0,6 / 2000	1,94 2,29
■ KRP 24 A R ... ■ KRP 25 A R ...	■ KRP 24 A L ... ■ KRP 25 A L ...	Tr 24x5 Tr 25x5	1 1	200 200	0,4 / 2000 0,4 / 2000	2,78 3,05
■ KRP 26 A R ... ■ KRP 28 A R ...	□ KRP 26 A L ... □ KRP 28 A L ...	Tr 26x5 Tr 28x5	1 1	200 200	0,4 / 2000 0,4 / 2000	3,33 3,92
□ KRP 30 P R ... ■ KRP 30 A R ...	□ KRP 30 P L ... ■ KRP 30 A L ...	Tr 30x5 Tr 30x6	1 1	200 200	0,4 / 3000 0,4 / 3000	4,57 4,38
□ KRP 32 A R ... □ KRP 35 P R ...	□ KRP 32 A L ... □ KRP 35 P L ...	Tr 32x6 Tr 35x5	1 1	200 200	0,4 / 3000 0,3 / 3000	5,06 6,40
■ KRP 35 A R ... ■ KRP 36 A R ...	■ KRP 35 A L ... ■ KRP 36 A L ...	Tr 35x6 Tr 36x6	1 1	200 200	0,3 / 3000 0,3 / 3000	6,16 6,56
□ KRP 40 P R ... □ KRP 40 O R ...	□ KRP 40 P L ... □ KRP 40 O L ...	Tr 40x5 Tr 40x6	1 1	200 200	0,3 / 3000 0,3 / 3000	8,51 8,26
■ KRP 40 A R ... □ KRP 44 A R ...	■ KRP 40 A L ... □ KRP 44 A L ...	Tr 40x7 Tr 44x7	1 1	200 200	0,3 / 3000 0,3 / 3000	8,03 9,90
□ KRP 50 P R ... □ KRP 50 O R ...	□ KRP 50 P L ... □ KRP 50 O L ...	Tr 50x5 Tr 50x6	1 1	200 200	0,3 / 3000 0,3 / 3000	13,70 13,35
■ KRP 50 A R ... □ KRP 55 A R ...	■ KRP 50 A L ... □ KRP 55 A L ...	Tr 50x8 Tr 55x9	1 1	200 200	0,3 / 3000 0,3 / 3000	12,90 15,51
□ KRP 60 O R ... □ KRP 60 N R ... ■ KRP 60 A R ...	□ KRP 60 O L ... □ KRP 60 N L ... ■ KRP 60 A L ...	Tr 60x6 Tr 60x7 Tr 60x9	1 1 1	200 200 200	0,3 / 3000 0,3 / 3000 0,3 / 3000	19,67 19,36 18,74
■ KRP 70 A R ... ■ KRP 80 A R ...	■ KRP 70 A L ... ■ KRP 80 A L ...	Tr 70x10 Tr 80x10	1 1	200 200	0,3 / 3000 0,3 / 3000	25,80 34,39
■ KRP 90 A R ... ■ KRP A0 A R ...	□ KRP 90 A L ... □ KRP A0 A L ...	Tr 90x12 Tr 100x12	1 1	200 200	1 / 300 1 / 300	43,07 53,99

■ = Goods in stock.

□ = Goods available upon request only.

Trapezoidal screws type KRE

A2 stainless steel - AISI 304 1.4301

Stock no. for screw RIGHT	Stock no. for screw LEFT	Diameter x lead	Thread starts	Lead accuracy μm / 300 mm	Straightness mm / mm	Weight kg/mt
□ KRE 10 T R ...	□ KRE 10 T L ...	Tr 10x2	1	200	1,5 / 300	0,48
□ KRE 10 A R ...	□ KRE 10 A L ...	Tr 10x3	1	200	1,5 / 300	0,42
■ KRE 12 A R ...	■ KRE 12 A L ...	Tr 12x3	1	200	1,5 / 300	0,65
□ KRE 14 R R ...	□ KRE 14 R L ...	Tr 14x3	1	200	1,5 / 300	0,93
■ KRE 14 A R ...	■ KRE 14 A L ...	Tr 14x4	1	200	1,5 / 300	0,86
■ KRE 16 A R ...	■ KRE 16 A L ...	Tr 16x4	1	200	1,5 / 300	1,17
■ KRE 18 A R ...	■ KRE 18 A L ...	Tr 18x4	1	200	1,5 / 300	1,53
■ KRE 20 A R ...	■ KRE 20 A L ...	Tr 20x4	1	200	1,5 / 300	1,94
□ KRE 22 A R ...	□ KRE 22 A L ...	Tr 22x5	1	200	1,5 / 300	2,29
■ KRE 24 A R ...	■ KRE 24 A L ...	Tr 24x5	1	200	1,5 / 300	2,78
■ KRE 25 A R ...	■ KRE 25 A L ...	Tr 25x5	1	200	1,5 / 300	3,05
■ KRE 26 A R ...	□ KRE 26 A L ...	Tr 26x5	1	200	1,5 / 300	3,33
■ KRE 28 A R ...	□ KRE 28 A L ...	Tr 28x5	1	200	1,5 / 300	3,92
□ KRE 30 P R ...	□ KRE 30 P L ...	Tr 30x5	1	200	1,5 / 300	4,57
■ KRE 30 A R ...	■ KRE 30 A L ...	Tr 30x6	1	200	1,5 / 300	4,38
□ KRE 32 A R ...	□ KRE 32 A L ...	Tr 32x6	1	200	1,5 / 300	5,06
□ KRE 35 P R ...	□ KRE 35 P L ...	Tr 35x5	1	200	1,5 / 300	6,40
■ KRE 35 A R ...	■ KRE 35 A L ...	Tr 35x6	1	200	1,5 / 300	6,16
■ KRE 36 A R ...	■ KRE 36 A L ...	Tr 36x6	1	200	1,5 / 300	6,56
□ KRE 40 P R ...	□ KRE 40 P L ...	Tr 40x5	1	200	1,5 / 300	8,51
□ KRE 40 O R ...	□ KRE 40 O L ...	Tr 40x6	1	200	1,5 / 300	8,26
■ KRE 40 A R ...	■ KRE 40 A L ...	Tr 40x7	1	200	1,5 / 300	8,03
□ KRE 44 A R ...	□ KRE 44 A L ...	Tr 44x7	1	200	1,5 / 300	9,90
□ KRE 50 P R ...	□ KRE 50 P L ...	Tr 50x5	1	200	1,5 / 300	13,70
□ KRE 50 O R ...	□ KRE 50 O L ...	Tr 50x6	1	200	1,5 / 300	13,35
■ KRE 50 A R ...	■ KRE 50 A L ...	Tr 50x8	1	200	1,5 / 300	12,90
□ KRE 55 A R ...	□ KRE 55 A L ...	Tr 55x9	1	200	1,5 / 300	15,51
□ KRE 60 O R ...	□ KRE 60 O L ...	Tr 60x6	1	200	1,5 / 300	19,67
□ KRE 60 N R ...	□ KRE 60 N L ...	Tr 60x7	1	200	1,5 / 300	19,36
■ KRE 60 A R ...	■ KRE 60 A L ...	Tr 60x9	1	200	1,5 / 300	18,74
■ KRE 70 A R ...	■ KRE 70 A L ...	Tr 70x10	1	200	1,5 / 300	25,80
■ KRE 80 A R ...	■ KRE 80 A L ...	Tr 80x10	1	200	1,5 / 300	34,39
■ KRE 90 A R ...	□ KRE 90 A L ...	Tr 90x12	1	200	1,5 / 300	43,07
■ KRE A0 A R ...	□ KRE A0 A L ...	Tr 100x12	1	200	1,5 / 300	53,99

■ = Goods in stock.

□ = Goods available upon request only.

Trapezoidal screws type KAM

A4 stainless steel - AISI 316 1.4401

Stock no. for screw RIGHT	Stock no. for screw LEFT	Diameter x lead	Thread starts	Lead accuracy µm / 300 mm	Straightness mm / mm	Weight kg/mt
■ KAM 10 T R ...	□ KAM 10 T L ...	Tr 10x2	1	200	0,7 / 1000	0,48
□ KAM 10 A R ...	□ KAM 10 A L ...	Tr 10x3	1	200	0,7 / 1000	0,42
■ KAM 12 A R ...	■ KAM 12 A L ...	Tr 12x3	1	200	0,7 / 1000	0,65
■ KAM 14 R R ...	□ KAM 14 R L ...	Tr 14x3	1	200	0,7 / 1000	0,93
□ KAM 14 A R ...	□ KAM 14 A L ...	Tr 14x4	1	200	0,7 / 1000	0,86
■ KAM 16 A R ...	■ KAM 16 A L ...	Tr 16x4	1	200	0,7 / 1500	1,17
■ KAM 18 A R ...	□ KAM 18 A L ...	Tr 18x4	1	200	0,7 / 1500	1,53
■ KAM 20 A R ...	■ KAM 20 A L ...	Tr 20x4	1	200	0,6 / 2000	1,94
■ KAM 22 A R ...	□ KAM 22 A L ...	Tr 22x5	1	200	0,6 / 2000	2,29
■ KAM 24 A R ...	■ KAM 24 A L ...	Tr 24x5	1	200	0,4 / 2000	2,78
□ KAM 25 A R ...	□ KAM 25 A L ...	Tr 25x5	1	200	0,4 / 2000	3,05
■ KAM 26 A R ...	□ KAM 26 A L ...	Tr 26x5	1	200	0,4 / 2000	3,33
■ KAM 28 A R ...	□ KAM 28 A L ...	Tr 28x5	1	200	0,4 / 2000	3,92
□ KAM 30 P R ...	□ KAM 30 P L ...	Tr 30x5	1	200	0,4 / 3000	4,57
■ KAM 30 A R ...	■ KAM 30 A L ...	Tr 30x6	1	200	0,4 / 3000	4,38
■ KAM 32 A R ...	■ KAM 32 A L ...	Tr 32x6	1	200	0,4 / 3000	5,06
□ KAM 35 P R ...	□ KAM 35 P L ...	Tr 35x5	1	200	0,3 / 3000	6,40
□ KAM 35 A R ...	□ KAM 35 A L ...	Tr 35x6	1	200	0,3 / 3000	6,16
■ KAM 36 A R ...	■ KAM 36 A L ...	Tr 36x6	1	200	0,3 / 3000	6,56
□ KAM 40 P R ...	□ KAM 40 P L ...	Tr 40x5	1	200	0,3 / 3000	8,51
□ KAM 40 O R ...	□ KAM 40 O L ...	Tr 40x6	1	200	0,3 / 3000	8,26
■ KAM 40 A R ...	■ KAM 40 A L ...	Tr 40x7	1	200	0,3 / 3000	8,03
□ KAM 44 A R ...	□ KAM 44 A L ...	Tr 44x7	1	200	0,3 / 3000	9,90
□ KAM 50 P R ...	□ KAM 50 P L ...	Tr 50x5	1	200	0,3 / 3000	13,70
□ KAM 50 O R ...	□ KAM 50 O L ...	Tr 50x6	1	200	0,3 / 3000	13,35
■ KAM 50 A R ...	■ KAM 50 A L ...	Tr 50x8	1	200	0,3 / 3000	12,90
□ KAM 55 A R ...	□ KAM 55 A L ...	Tr 55x9	1	200	0,3 / 3000	15,51
□ KAM 60 O R ...	□ KAM 60 O L ...	Tr 60x6	1	200	0,3 / 3000	19,67
□ KAM 60 N R ...	□ KAM 60 N L ...	Tr 60x7	1	200	0,3 / 3000	19,36
■ KAM 60 A R ...	■ KAM 60 A L ...	Tr 60x9	1	200	0,3 / 3000	18,74
■ KAM 70 A R ...	■ KAM 70 A L ...	Tr 70x10	1	200	0,3 / 3000	25,80
■ KAM 80 A R ...	■ KAM 80 A L ...	Tr 80x10	1	200	0,3 / 3000	34,39
■ KAM 90 A R ...	□ KAM 90 A L ...	Tr 90x12	1	200	1 / 300	43,07
■ KAM A0 A R ...	□ KAM A0 A L ...	Tr 100x12	1	200	1 / 300	53,99

■ = Goods in stock.

□ = Goods available upon request only.

Trapezoidal screws type KAF

A4 stainless steel - AISI 316 1.4401

Stock no. for screw RIGHT	Stock no. for screw LEFT	Diameter x lead	Thread starts	Lead accuracy µm / 300 mm	Straightness mm / mm	Weight kg/mt
■ KAF 10 T R ...	□ KAF 10 T L ...	Tr 10x2	1	200	1,5 / 300	0,48
□ KAF 10 A R ...	□ KAF 10 A L ...	Tr 10x3	1	200	1,5 / 300	0,42
■ KAF 12 A R ...	■ KAF 12 A L ...	Tr 12x3	1	200	1,5 / 300	0,65
■ KAF 14 R R ...	□ KAF 14 R L ...	Tr 14x3	1	200	1,5 / 300	0,93
□ KAF 14 A R ...	□ KAF 14 A L ...	Tr 14x4	1	200	1,5 / 300	0,86
■ KAF 16 A R ...	■ KAF 16 A L ...	Tr 16x4	1	200	1,5 / 300	1,17
■ KAF 18 A R ...	□ KAF 18 A L ...	Tr 18x4	1	200	1,5 / 300	1,53
■ KAF 20 A R ...	■ KAF 20 A L ...	Tr 20x4	1	200	1,5 / 300	1,94
■ KAF 22 A R ...	□ KAF 22 A L ...	Tr 22x5	1	200	1,5 / 300	2,29
■ KAF 24 A R ...	■ KAF 24 A L ...	Tr 24x5	1	200	1,5 / 300	2,78
□ KAF 25 A R ...	□ KAF 25 A L ...	Tr 25x5	1	200	1,5 / 300	3,05
■ KAF 26 A R ...	□ KAF 26 A L ...	Tr 26x5	1	200	1,5 / 300	3,33
■ KAF 28 A R ...	□ KAF 28 A L ...	Tr 28x5	1	200	1,5 / 300	3,92
□ KAF 30 P R ...	□ KAF 30 P L ...	Tr 30x5	1	200	1,5 / 300	4,57
■ KAF 30 A R ...	■ KAF 30 A L ...	Tr 30x6	1	200	1,5 / 300	4,38
■ KAF 32 A R ...	■ KAF 32 A L ...	Tr 32x6	1	200	1,5 / 300	5,06
□ KAF 35 P R ...	□ KAF 35 P L ...	Tr 35x5	1	200	1,5 / 300	6,40
□ KAF 35 A R ...	□ KAF 35 A L ...	Tr 35x6	1	200	1,5 / 300	6,16
■ KAF 36 A R ...	■ KAF 36 A L ...	Tr 36x6	1	200	1,5 / 300	6,56
□ KAF 40 P R ...	□ KAF 40 P L ...	Tr 40x5	1	200	1,5 / 300	8,51
□ KAF 40 O R ...	□ KAF 40 O L ...	Tr 40x6	1	200	1,5 / 300	8,26
■ KAF 40 A R ...	■ KAF 40 A L ...	Tr 40x7	1	200	1,5 / 300	8,03
□ KAF 44 A R ...	□ KAF 44 A L ...	Tr 44x7	1	200	1,5 / 300	9,90
□ KAF 50 P R ...	□ KAF 50 P L ...	Tr 50x5	1	200	1,5 / 300	13,70
□ KAF 50 O R ...	□ KAF 50 O L ...	Tr 50x6	1	200	1,5 / 300	13,35
■ KAF 50 A R ...	■ KAF 50 A L ...	Tr 50x8	1	200	1,5 / 300	12,90
□ KAF 55 A R ...	□ KAF 55 A L ...	Tr 55x9	1	200	1,5 / 300	15,51
□ KAF 60 O R ...	□ KAF 60 O L ...	Tr 60x6	1	200	1,5 / 300	19,67
□ KAF 60 N R ...	□ KAF 60 N L ...	Tr 60x7	1	200	1,5 / 300	19,36
■ KAF 60 A R ...	■ KAF 60 A L ...	Tr 60x9	1	200	1,5 / 300	18,74
■ KAF 70 A R ...	■ KAF 70 A L ...	Tr 70x10	1	200	1,5 / 300	25,80
■ KAF 80 A R ...	■ KAF 80 A L ...	Tr 80x10	1	200	1,5 / 300	34,39
■ KAF 90 A R ...	□ KAF 90 A L ...	Tr 90x12	1	200	1,5 / 300	43,07
■ KAF A0 A R ...	□ KAF A0 AL ...	Tr 100x12	1	200	1,5 / 300	53,99

■ = Goods in stock.

□ = Goods available upon request only.

Trapezoidal screws type KTS – Steel C45 1.0503

Stock no. for screw RIGHT	Stock no. for screw LEFT	Diameter x lead	Thread starts	Lead accuracy µm /300 mm	Straightness mm / mm	Weight kg/mt
■ KTS 10 J R ...	□ KTS 10 J L ...	Tr 10x4 (P2)	2	100	0,5 / 1000	0,48
■ KTS 12 B R ...	□ KTS 12 B L ...	Tr 12x6 (P3)	2	100	0,5 / 1000	0,65
■ KTS 14 B R ...	□ KTS 14 B L ...	Tr 14x6 (P3)	2	100	0,5 / 1000	0,93
■ KTS 16 B R ...	□ KTS 16 B L ...	Tr 16x8 (P4)	2	100	0,5 / 1000	1,17
■ KTS 18 B R ...	□ KTS 18 B L ...	Tr 18x8 (P4)	2	100	0,5 / 1000	1,53
■ KTS 20 B R ...	□ KTS 20 B L ...	Tr 20x8 (P4)	2	100	0,4 / 2000	1,94
□ KTS 20 D R ...	□ KTS 20 D L ...	Tr 20x20 (P5)	4	100	0,4 / 2000	1,84
■ KTS 22 B R ...	□ KTS 22 B L ...	Tr 22x10 (P5)	2	100	0,4 / 2000	2,29
■ KTS 24 B R ...	□ KTS 24 B L ...	Tr 24x10 (P5)	2	100	0,4 / 2000	2,78
□ KTS 25 B R ...	□ KTS 25 B L ...	Tr 25x10 (P5)	2	100	0,3 / 2000	3,05
■ KTS 25 E R ...	□ KTS 25 E L ...	Tr 25x25 (P5)	5	100	0,3 / 2000	3,05
■ KTS 26 B R ...	□ KTS 26 B L ...	Tr 26x10 (P5)	2	100	0,3 / 2000	3,33
■ KTS 28 B R ...	□ KTS 28 B L ...	Tr 28x10 (P5)	2	100	0,3 / 2000	3,92
■ KTS 30 B R ...	□ KTS 30 B L ...	Tr 30x12 (P6)	2	100	0,3 / 3000	4,38
□ KTS 30 F R ...	□ KTS 30 F L ...	Tr 30x30 (P5)	6	100	0,3 / 3000	4,57
■ KTS 32 B R ...	□ KTS 32 B L ...	Tr 32x12 (P6)	2	100	0,3 / 3000	5,06
■ KTS 36 B R ...	□ KTS 36 B L ...	Tr 36x12 (P6)	2	100	0,3 / 3000	6,56
■ KTS 40 B R ...	□ KTS 40 B L ...	Tr 40x14 (P7)	2	100	0,3 / 3000	8,03
□ KTS 40 E R ...	□ KTS 40 E L ...	Tr 40x40 (P8)	5	100	0,3 / 3000	7,90

■ = Goods in stock.

□ = Goods available upon request only.

Trapezoidal screws type KUE – Steel C45 1.0503

Stock no. for screw RIGHT	Stock no. for screw LEFT	Diameter x lead	Thread starts	Lead accuracy µm /300 mm	Straightness mm / mm	Weight kg/mt
■ KUE 10 J R ...	□ KUE 10 J L ...	Tr 10x4 (P2)	2	100	0,5 / 300	0,48
■ KUE 12 B R ...	□ KUE 12 B L ...	Tr 12x6 (P3)	2	100	0,5 / 300	0,65
■ KUE 14 B R ...	□ KUE 14 B L ...	Tr 14x6 (P3)	2	100	0,5 / 300	0,93
■ KUE 16 B R ...	□ KUE 16 B L ...	Tr 16x8 (P4)	2	100	0,5 / 300	1,17
■ KUE 18 B R ...	□ KUE 18 B L ...	Tr 18x8 (P4)	2	100	0,5 / 300	1,53
■ KUE 20 B R ...	□ KUE 20 B L ...	Tr 20x8 (P4)	2	100	0,4 / 300	1,94
□ KUE 20 D R ...	□ KUE 20 D L ...	Tr 20x20 (P5)	4	100	0,4 / 300	1,84
■ KUE 22 B R ...	□ KUE 22 B L ...	Tr 22x10 (P5)	2	100	0,3 / 300	2,29
■ KUE 24 B R ...	□ KUE 24 B L ...	Tr 24x10 (P5)	2	100	0,3 / 300	2,78
□ KUE 25 B R ...	□ KUE 25 B L ...	Tr 25x10 (P5)	2	100	0,3 / 300	3,05
■ KUE 25 E R ...	□ KUE 25 E L ...	Tr 25x25 (P5)	5	100	0,3 / 300	3,05
■ KUE 26 B R ...	□ KUE 26 B L ...	Tr 26x10 (P5)	2	100	0,3 / 300	3,33
■ KUE 28 B R ...	□ KUE 28 B L ...	Tr 28x10 (P5)	2	100	0,3 / 300	3,92
■ KUE 30 B R ...	□ KUE 30 B L ...	Tr 30x12 (P6)	2	100	0,3 / 300	4,38
□ KUE 30 F R ...	□ KUE 30 F L ...	Tr 30x30 (P5)	6	100	0,3 / 300	4,57
■ KUE 32 B R ...	□ KUE 32 B L ...	Tr 32x12 (P6)	2	100	0,3 / 300	5,06
■ KUE 36 B R ...	□ KUE 36 B L ...	Tr 36x12 (P6)	2	100	0,3 / 300	6,56
■ KUE 40 B R ...	□ KUE 40 B L ...	Tr 40x14 (P7)	2	100	0,3 / 300	8,03
□ KUE 40 E R ...	□ KUE 40 E L ...	Tr 40x40 (P8)	5	100	0,3 / 300	7,90

■ = Goods in stock.

□ = Goods available upon request only.

Trapezoidal screws type KKA – Steel C45 1.0503

Stock no. for screw RIGHT	Stock no. for screw LEFT	Diameter x lead	Thread starts	Lead accuracy µm / 300 mm	Straightness mm / mm	Weight kg/mt
<input type="checkbox"/> KKA 10 J R ... <input type="checkbox"/> KKA 12 B R ...	<input type="checkbox"/> KKA 10 J L ... <input type="checkbox"/> KKA 12 B L ...	Tr 10x4 (P2) Tr 12x6 (P3)	2 2	50 50	0,5 / 1000 0,5 / 1000	0,48 0,65
<input type="checkbox"/> KKA 14 B R ... <input type="checkbox"/> KKA 16 B R ... <input type="checkbox"/> KKA 18 B R ...	<input type="checkbox"/> KKA 14 B L ... <input type="checkbox"/> KKA 16 B L ... <input type="checkbox"/> KKA 18 B L ...	Tr 14x6 (P3) Tr 16x8 (P4) Tr 18x8 (P4)	2 2 2	50 50 50	0,5 / 1000 0,5 / 1000 0,5 / 1000	0,93 1,17 1,53
<input type="checkbox"/> KKA 20 B R ... <input type="checkbox"/> KKA 20 D R ...	<input type="checkbox"/> KKA 20 B L ... <input type="checkbox"/> KKA 20 D L ...	Tr 20x8 (P4) Tr 20x20 (P5)	2 4	50 50	0,4 / 2000 0,4 / 2000	1,94 1,84
<input type="checkbox"/> KKA 22 B R ... <input type="checkbox"/> KKA 24 B R ...	<input type="checkbox"/> KKA 22 B L ... <input type="checkbox"/> KKA 24 B L ...	Tr 22x10 (P5) Tr 24x10 (P5)	2 2	50 50	0,4 / 2000 0,4 / 2000	2,29 2,78
<input type="checkbox"/> KKA 25 B R ... <input type="checkbox"/> KKA 25 E R ...	<input type="checkbox"/> KKA 25 B L ... <input type="checkbox"/> KKA 25 E L ...	Tr 25x10 (P5) Tr 25x25 (P5)	2 5	50 50	0,3 / 2000 0,3 / 2000	3,05 3,05
<input type="checkbox"/> KKA 26 B R ... <input type="checkbox"/> KKA 28 B R ...	<input type="checkbox"/> KKA 26 B L ... <input type="checkbox"/> KKA 28 B L ...	Tr 26x10 (P5) Tr 28x10 (P5)	2 2	50 50	0,3 / 2000 0,3 / 2000	3,33 3,92
<input type="checkbox"/> KKA 30 B R ... <input type="checkbox"/> KKA 30 F R ...	<input type="checkbox"/> KKA 30 B L ... <input type="checkbox"/> KKA 30 F L ...	Tr 30x12 (P6) Tr 30x30 (P5)	2 6	50 50	0,3 / 3000 0,3 / 3000	4,38 4,57
<input type="checkbox"/> KKA 32 B R ... <input type="checkbox"/> KKA 36 B R ...	<input type="checkbox"/> KKA 32 B L ... <input type="checkbox"/> KKA 36 B L ...	Tr 32x12 (P6) Tr 36x12 (P6)	2 2	50 50	0,3 / 3000 0,3 / 3000	5,06 6,56
<input type="checkbox"/> KKA 40 B R ... <input type="checkbox"/> KKA 40 E R ...	<input type="checkbox"/> KKA 40 B L ... <input type="checkbox"/> KKA 40 E L ...	Tr 40x14 (P7) Tr 40x40 (P8)	2 5	50 50	0,3 / 3000 0,3 / 3000	8,03 7,90

■ = Goods in stock.

□ = Goods available upon request only.

Trapezoidal screws type KQX – Steel C15 1.1141

Stock no. for screw RIGHT	Stock no. for screw LEFT	Diameter x lead	Thread starts	Lead accuracy µm /300 mm	Straightness mm / mm	Weight kg/mt
□ KQX 10 J R ... ■ KQX 12 B R ...	□ KQX 10 J L ... □ KQX 12 B L ...	Tr 10x4 (P2) Tr 12x6 (P3)	2 2	200 200	0,7 / 1000 0,7 / 1000	0,48 0,65
□ KQX 14 B R ... ■ KQX 16 B R ... □ KQX 18 B R ...	□ KQX 14 B L ... □ KQX 16 B L ... □ KQX 18 B L ...	Tr 14x6 (P3) Tr 16x8 (P4) Tr 18x8 (P4)	2 2 2	200 200 200	0,7 / 1000 0,7 / 1500 0,7 / 1500	0,93 1,17 1,53
■ KQX 20 B R ... ■ KQX 20 D R ...	□ KQX 20 B L ... □ KQX 20 D L ...	Tr 20x8 (P4) Tr 20x20 (P5)	2 4	200 200	0,6 / 2000 0,6 / 2000	1,94 1,84
□ KQX 22 B R ... □ KQX 24 B R ...	□ KQX 22 B L ... □ KQX 24 B L ...	Tr 22x10 (P5) Tr 24x10 (P5)	2 2	200 200	0,6 / 2000 0,4 / 2000	2,29 2,78
■ KQX 25 B R ... ■ KQX 25 E R ...	□ KQX 25 B L ... □ KQX 25 E L ...	Tr 25x10 (P5) Tr 25x25 (P5)	2 5	200 200	0,4 / 2000 0,4 / 2000	3,05 3,05
□ KQX 26 B R ... ■ KQX 28 B R ...	□ KQX 26 B L ... □ KQX 28 B L ...	Tr 26x10 (P5) Tr 28x10 (P5)	2 2	200 200	0,4 / 2000 0,4 / 2000	3,33 3,92
■ KQX 30 B R ... ■ KQX 30 F R ...	□ KQX 30 B L ... □ KQX 30 F L ...	Tr 30x12 (P6) Tr 30x30 (P5)	2 6	200 200	0,4 / 3000 0,4 / 3000	4,38 4,57
□ KQX 32 B R ... □ KQX 36 B R ...	□ KQX 32 B L ... □ KQX 36 B L ...	Tr 32x12 (P6) Tr 36x12 (P6)	2 2	200 200	0,4 / 3000 0,3 / 3000	5,06 6,56
■ KQX 40 B R ... ■ KQX 40 E R ...	□ KQX 40 B L ... □ KQX 40 E L ...	Tr 40x14 (P7) Tr 40x40 (P8)	2 5	200 200	0,3 / 3000 0,3 / 3000	8,03 7,90

■ = Goods in stock.

□ = Goods available upon request only.

Trapezoidal screws type KEQ – Steel C15 1.1141

Stock no. for screw RIGHT	Stock no. for screw LEFT	Diameter x lead	Thread starts	Lead accuracy µm /300 mm	Straightness mm / mm	Weight kg/mt
□ KEQ 10 J R ... □ KEQ 12 B R ...	□ KEQ 10 J L ... □ KEQ 12 B L ...	Tr 10x4 (P2) Tr 12x6 (P3)	2 2	200 200	-- --	0,48 0,65
□ KEQ 14 B R ... □ KEQ 16 B R ... □ KEQ 18 B R ...	□ KEQ 14 B L ... □ KEQ 16 B L ... □ KEQ 18 B L ...	Tr 14x6 (P3) Tr 16x8 (P4) Tr 18x8 (P4)	2 2 2	200 200 200	-- -- --	0,93 1,17 1,53
□ KEQ 20 B R ... □ KEQ 20 D R ...	□ KEQ 20 B L ... □ KEQ 20 D L ...	Tr 20x8 (P4) Tr 20x20 (P5)	2 4	200 200	-- --	1,94 1,84
□ KEQ 22 B R ... □ KEQ 24 B R ...	□ KEQ 22 B L ... □ KEQ 24 B L ...	Tr 22x10 (P5) Tr 24x10 (P5)	2 2	200 200	-- --	2,29 2,78
□ KEQ 25 B R ... □ KEQ 25 E R ...	□ KEQ 25 B L ... □ KEQ 25 E L ...	Tr 25x10 (P5) Tr 25x25 (P5)	2 5	200 200	-- --	3,05 3,05
□ KEQ 26 B R ... □ KEQ 28 B R ...	□ KEQ 26 B L ... □ KEQ 28 B L ...	Tr 26x10 (P5) Tr 28x10 (P5)	2 2	200 200	-- --	3,33 3,92
□ KEQ 30 B R ... □ KEQ 30 F R ...	□ KEQ 30 B L ... □ KEQ 30 F L ...	Tr 30x12 (P6) Tr 30x30 (P5)	2 6	200 200	-- --	4,38 4,57
□ KEQ 32 B R ... □ KEQ 36 B R ...	□ KEQ 32 B L ... □ KEQ 36 B L ...	Tr 32x12 (P6) Tr 36x12 (P6)	2 2	200 200	-- --	5,06 6,56
□ KEQ 40 B R ... □ KEQ 40 E R ...	□ KEQ 40 B L ... □ KEQ 40 E L ...	Tr 40x14 (P7) Tr 40x40 (P8)	2 5	200 200	-- --	8,03 7,90

■ = Goods in stock.

□ = Goods available upon request only.

Trapezoidal screws type KRP

A2 stainless steel - AISI 304 1.4301

Stock no. for screw RIGHT	Stock no. for screw LEFT	Diameter x lead	Thread starts	Lead accuracy $\mu\text{m} / 300 \text{ mm}$	Straightness mm / mm	Weight kg/mt
<input type="checkbox"/> KRP 10 J R ... <input checked="" type="checkbox"/> KRP 12 B R ...	<input type="checkbox"/> KRP 10 J L ... <input type="checkbox"/> KRP 12 B L ...	Tr 10x4 (P2) Tr 12x6 (P3)	2 2	200 200	0,7 / 1000 0,7 / 1000	0,48 0,65
<input type="checkbox"/> KRP 14 B R ... <input checked="" type="checkbox"/> KRP 16 B R ...	<input type="checkbox"/> KRP 14 B L ... <input type="checkbox"/> KRP 16 B L ...	Tr 14x6 (P3) Tr 16x8 (P4)	2 2	200 200	0,7 / 1000 0,7 / 1500	0,93 1,17
<input type="checkbox"/> KRP 18 B R ... <input checked="" type="checkbox"/> KRP 20 B R ...	<input type="checkbox"/> KRP 18 B L ... <input type="checkbox"/> KRP 20 B L ...	Tr 18x8 (P4) Tr 20x8 (P4)	2 2	200 200	0,7 / 1500 0,6 / 2000	1,53 1,94
<input type="checkbox"/> KRP 20 D R ... <input type="checkbox"/> KRP 22 B R ...	<input type="checkbox"/> KRP 20 D L ... <input type="checkbox"/> KRP 22 B L ...	Tr 20x20 (P5) Tr 22x10 (P5)	4 2	200 200	0,4 / 2000 0,4 / 2000	1,84 2,29
<input type="checkbox"/> KRP 24 B R ... <input checked="" type="checkbox"/> KRP 25 B R ...	<input type="checkbox"/> KRP 24 B L ... <input type="checkbox"/> KRP 25 B L ...	Tr 24x10 (P5) Tr 25x10 (P5)	2 2	200 200	0,4 / 2000 0,4 / 2000	2,78 3,05
<input type="checkbox"/> KRP 26 B R ... <input type="checkbox"/> KRP 28 B R ...	<input type="checkbox"/> KRP 26 B L ... <input type="checkbox"/> KRP 28 B L ...	Tr 26x10 (P5) Tr 28x10 (P5)	2 2	200 200	0,4 / 2000 0,4 / 2000	3,33 3,92
<input checked="" type="checkbox"/> KRP 30 B R ... <input type="checkbox"/> KRP 32 B R ...	<input type="checkbox"/> KRP 30 B L ... <input type="checkbox"/> KRP 32 B L ...	Tr 30x12 (P6) Tr 32x12 (P6)	2 2	200 200	0,4 / 3000 0,4 / 3000	4,38 5,06
<input type="checkbox"/> KRP 36 B R ... <input checked="" type="checkbox"/> KRP 40 B R ...	<input type="checkbox"/> KRP 36 B L ... <input type="checkbox"/> KRP 40 B L ...	Tr 36x12 (P6) Tr 40x14 (P7)	2 2	200 200	0,3 / 3000 0,3 / 3000	6,56 8,03

■ = Goods in stock.

□ = Goods available upon request only.

Trapezoidal screws type KRE

A2 stainless steel - AISI 304 1.4301

Stock no. for screw RIGHT	Stock no. for screw LEFT	Diameter x lead	Thread starts	Lead accuracy $\mu\text{m} / 300 \text{ mm}$	Straightness mm / mm	Weight kg/mt
<input type="checkbox"/> KRE 10 J R ... <input checked="" type="checkbox"/> KRE 12 B R ...	<input type="checkbox"/> KRE 10 J L ... <input type="checkbox"/> KRE 12 B L ...	Tr 10x4 (P2) Tr 12x6 (P3)	2 2	200 200	1,5 / 300 1,5 / 300	0,48 0,65
<input type="checkbox"/> KRE 14 B R ... <input checked="" type="checkbox"/> KRE 16 B R ...	<input type="checkbox"/> KRE 14 B L ... <input type="checkbox"/> KRE 16 B L ...	Tr 14x6 (P3) Tr 16x8 (P4)	2 2	200 200	1,5 / 300 1,5 / 300	0,93 1,17
<input type="checkbox"/> KRE 18 B R ... <input checked="" type="checkbox"/> KRE 20 B R ...	<input type="checkbox"/> KRE 18 B L ... <input type="checkbox"/> KRE 20 B L ...	Tr 18x8 (P4) Tr 20x8 (P4)	2 2	200 200	1,5 / 300 1,5 / 300	1,53 1,94
<input type="checkbox"/> KRE 20 D R ... <input type="checkbox"/> KRE 22 B R ...	<input type="checkbox"/> KRE 20 D L ... <input type="checkbox"/> KRE 22 B L ...	Tr 20x20 (P5) Tr 22x10 (P5)	4 2	200 200	1,5 / 300 1,5 / 300	1,84 2,29
<input type="checkbox"/> KRE 24 B R ... <input checked="" type="checkbox"/> KRE 25 B R ...	<input type="checkbox"/> KRE 24 B L ... <input type="checkbox"/> KRE 25 B L ...	Tr 24x10 (P5) Tr 25x10 (P5)	2 2	200 200	1,5 / 300 1,5 / 300	2,78 3,05
<input type="checkbox"/> KRE 26 B R ... <input type="checkbox"/> KRE 28 B R ...	<input type="checkbox"/> KRE 26 B L ... <input type="checkbox"/> KRE 28 B L ...	Tr 26x10 (P5) Tr 28x10 (P5)	2 2	200 200	1,5 / 300 1,5 / 300	3,33 3,92
<input checked="" type="checkbox"/> KRE 30 B R ... <input type="checkbox"/> KRE 32 B R ...	<input type="checkbox"/> KRE 30 B L ... <input type="checkbox"/> KRE 32 B L ...	Tr 30x12 (P6) Tr 32x12 (P6)	2 2	200 200	1,5 / 300 1,5 / 300	4,38 5,06
<input type="checkbox"/> KRE 36 B R ... <input checked="" type="checkbox"/> KRE 40 B R ...	<input type="checkbox"/> KRE 36 B L ... <input type="checkbox"/> KRE 40 B L ...	Tr 36x12 (P6) Tr 40x14 (P7)	2 2	200 200	1,5 / 300 1,5 / 300	6,56 8,03

■ = Goods in stock.

□ = Goods available upon request only.

Trapezoidal screws type KAM

A4 stainless steel - AISI 316 1.4401

Stock no. for screw RIGHT	Stock no. for screw LEFT	Diameter x lead	Thread starts	Lead accuracy $\mu\text{m} / 300 \text{ mm}$	Straightness mm / mm	Weight kg/mt
<input type="checkbox"/> KAM 10 J R ...	<input type="checkbox"/> KAM 10 J L ...	Tr 10x4 (P2)	2	200	0,7 / 1000	0,48
<input type="checkbox"/> KAM 12 B R ...	<input type="checkbox"/> KAM 12 B L ...	Tr 12x6 (P3)	2	200	0,7 / 1000	0,65
<input type="checkbox"/> KAM 14 B R ...	<input type="checkbox"/> KAM 14 B L ...	Tr 14x6 (P3)	2	200	0,7 / 1000	0,93
<input type="checkbox"/> KAM 16 B R ...	<input type="checkbox"/> KAM 16 B L ...	Tr 16x8 (P4)	2	200	0,7 / 1500	1,17
<input type="checkbox"/> KAM 18 B R ...	<input type="checkbox"/> KAM 18 B L ...	Tr 18x8 (P4)	2	200	0,7 / 1500	1,53
<input type="checkbox"/> KAM 20 B R ...	<input type="checkbox"/> KAM 20 B L ...	Tr 20x8 (P4)	2	200	0,6 / 2000	1,94
<input type="checkbox"/> KAM 20 D R ...	<input type="checkbox"/> KAM 20 D L ...	Tr 20x20 (P5)	4	200	0,6 / 2000	1,84
<input type="checkbox"/> KAM 22 B R ...	<input type="checkbox"/> KAM 22 B L ...	Tr 22x10 (P5)	2	200	0,6 / 2000	2,29
<input type="checkbox"/> KAM 24 B R ...	<input type="checkbox"/> KAM 24 B L ...	Tr 24x10 (P5)	2	200	0,4 / 2000	2,78
<input type="checkbox"/> KAM 25 B R ...	<input type="checkbox"/> KAM 25 B L ...	Tr 25x10 (P5)	2	200	0,4 / 2000	3,05
<input type="checkbox"/> KAM 26 B R ...	<input type="checkbox"/> KAM 26 B L ...	Tr 26x10 (P5)	2	200	0,4 / 2000	3,33
<input type="checkbox"/> KAM 28 B R ...	<input type="checkbox"/> KAM 28 B L ...	Tr 28x10 (P5)	2	200	0,4 / 2000	3,92
<input type="checkbox"/> KAM 30 B R ...	<input type="checkbox"/> KAM 30 B L ...	Tr 30x12 (P6)	2	200	0,4 / 3000	4,38
<input type="checkbox"/> KAM 32 B R ...	<input type="checkbox"/> KAM 32 B L ...	Tr 32x12 (P6)	2	200	0,4 / 3000	5,06
<input type="checkbox"/> KAM 36 B R ...	<input type="checkbox"/> KAM 36 B L ...	Tr 36x12 (P6)	2	200	0,3 / 3000	6,56
<input type="checkbox"/> KAM 40 B R ...	<input type="checkbox"/> KAM 40 B L ...	Tr 40x14 (P7)	2	200	0,3 / 3000	8,03

■ = Goods in stock.

□ = Goods available upon request only.

Trapezoidal screws type KAF

A4 stainless steel - AISI 316 1.4401

Stock no. for screw RIGHT	Stock no. for screw LEFT	Diameter x lead	Thread starts	Lead accuracy $\mu\text{m} / 300 \text{ mm}$	Straightness mm / mm	Weight kg/mt
<input type="checkbox"/> KAF 10 J R ...	<input type="checkbox"/> KAF 10 J L ...	Tr 10x4 (P2)	2	200	1,5 / 300	0,48
<input type="checkbox"/> KAF 12 B R ...	<input type="checkbox"/> KAF 12 B L ...	Tr 12x6 (P3)	2	200	1,5 / 300	0,65
<input type="checkbox"/> KAF 14 B R ...	<input type="checkbox"/> KAF 14 B L ...	Tr 14x6 (P3)	2	200	1,5 / 300	0,93
<input type="checkbox"/> KAF 16 B R ...	<input type="checkbox"/> KAF 16 B L ...	Tr 16x8 (P4)	2	200	1,5 / 300	1,17
<input type="checkbox"/> KAF 18 B R ...	<input type="checkbox"/> KAF 18 B L ...	Tr 18x8 (P4)	2	200	1,5 / 300	1,53
<input type="checkbox"/> KAF 20 B R ...	<input type="checkbox"/> KAF 20 B L ...	Tr 20x8 (P4)	2	200	1,5 / 300	1,94
<input type="checkbox"/> KAF 20 D R ...	<input type="checkbox"/> KAF 20 D L ...	Tr 20x20 (P5)	4	200	1,5 / 300	1,84
<input type="checkbox"/> KAF 22 B R ...	<input type="checkbox"/> KAF 22 B L ...	Tr 22x10 (P5)	2	200	1,5 / 300	2,29
<input type="checkbox"/> KAF 24 B R ...	<input type="checkbox"/> KAF 24 B L ...	Tr 24x10 (P5)	2	200	1,5 / 300	2,78
<input type="checkbox"/> KAF 25 B R ...	<input type="checkbox"/> KAF 25 B L ...	Tr 25x10 (P5)	2	200	1,5 / 300	3,05
<input type="checkbox"/> KAF 26 B R ...	<input type="checkbox"/> KAF 26 B L ...	Tr 26x10 (P5)	2	200	1,5 / 300	3,33
<input type="checkbox"/> KAF 28 B R ...	<input type="checkbox"/> KAF 28 B L ...	Tr 28x10 (P5)	2	200	1,5 / 300	3,92
<input type="checkbox"/> KAF 30 B R ...	<input type="checkbox"/> KAF 30 B L ...	Tr 30x12 (P6)	2	200	1,5 / 300	4,38
<input type="checkbox"/> KAF 32 B R ...	<input type="checkbox"/> KAF 32 B L ...	Tr 32x12 (P6)	2	200	1,5 / 300	5,06
<input type="checkbox"/> KAF 36 B R ...	<input type="checkbox"/> KAF 36 B L ...	Tr 36x12 (P6)	2	200	1,5 / 300	6,56
<input type="checkbox"/> KAF 40 B R ...	<input type="checkbox"/> KAF 40 B L ...	Tr 40x14 (P7)	2	200	1,5 / 300	8,03

■ = Goods in stock.

□ = Goods available upon request only.

Trapezoidal nut type MLF - Cylindrical steel

Material: EN 10277-3 11 S Mn Pb 37 – 1.0737

Nut for fastening or manual movement with small load; steel-to-steel coupling tends to seize. Can be MIG welded only. Electrode welding is not recommended because of the lead.

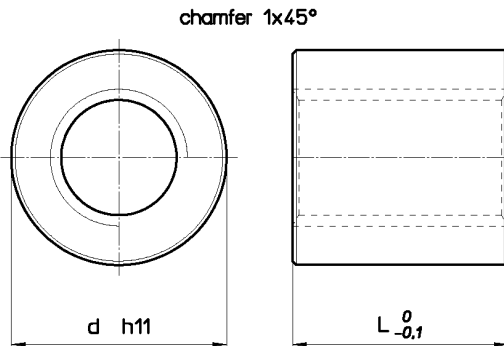

Nut Stock no. RIGHT	Nut Stock no. LEFT	Diameter x lead	Thread starts	d mm	L mm	Wt. kg/each	At mm ² (1)
MLF 12 A R	MLF 12 A L	Tr 12x3	1	36	36	0.255	592
MLF 12 B R	--	Tr 12x6 (P3)	2	36	36	0.255	592
MLF 14 A R	MLF 14 A L	Tr 14x4	1	36	36	0.250	677
MLF 16 A R	MLF 16 A L	Tr 16x4	1	36	36	0.238	792
MLF 16 B R	--	Tr 16x8 (P4)	2	36	36	0.238	792
MLF 18 A R	MLF 18 A L	Tr 18x4	1	36	36	0.224	905
MLF 20 A R	MLF 20 A L	Tr 20x4	1	40	40	0.306	1130
MLF 20 B R	--	Tr 20x8 (P4)	2	40	40	0.306	1130
MLF 22 A R	MLF 22 A L	Tr 22x5	1	40	40	0.290	1225
MLF 25 A R	MLF 25 A L	Tr 25x5	1	45	45	0.40	1590
MLF 25 B R	--	Tr 25x10 (P5)	2	45	45	0.40	1590
MLF 28 A R	MLF 28 A L	Tr 28x5	1	45	45	0.36	1800
MLF 28 B R	--	Tr 28x10 (P5)	2	45	45	0.36	1800
MLF 30 A R	MLF 30 A L	Tr 30x6	1	50	50	0.52	2120
MLF 30 B R	--	Tr 30x12 (P6)	2	50	50	0.52	2120
MLF 35 A R	MLF 35 A L	Tr 35x6	1	55	55	0.65	2764
MLF 40 A R	MLF 40 A L	Tr 40x7	1	60	60	0.79	3440
MLF 40 B R	--	Tr 40x14 (P7)	2	60	60	0.79	3440
MLF 45 A R	MLF 45 A L	Tr 45x8	1	65	65	0.95	4186
MLF 50 A R	MLF 50 A L	Tr 50x8	1	70	70	1.12	5057
MLF 55 A R	--	Tr 55x9	1	80	80	1.78	6345
MLF 60 A R	MLF 60 A L	Tr 60x9	1	80	80	1.51	6975

Trapezoidal nut type MZP - Cylindrical steel

Material: EN 10277-3 11 S Mn Pb 37 – 1.0737

Nut for fastening or manual movement with small load; steel-to-steel coupling tends to seize. Can be MIG welded only. Electrode welding is not recommended because of the lead.

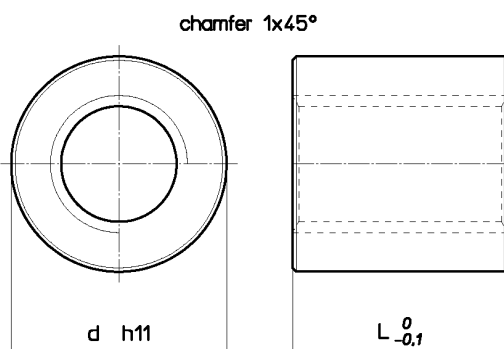

Nut Stock no. RIGHT	Nut Stock no. LEFT	Diameter x lead	Thread starts	d mm	L mm	Wt. kg/each	At mm ² (1)
MZP 10 T R	MZP 10 T L	Tr 10x2	1	22	15	0.038	150
MZP 10 A R	MZP 10 A L	Tr 10x3	1	22	15	0.037	240
MZP 12 A R	MZP 12 A L	Tr 12x3	1	26	18	0.061	296
MZP 12 B R	--	Tr 12x6 (P3)	2	26	18	0.061	296
MZP 14 R R	MZP 14 R L	Tr 14x3	1	30	21	0.095	395
MZP 14 A R	MZP 14 A L	Tr 14x4	1	30	21	0.095	395
MZP 16 A R	MZP 16 A L	Tr 16x4	1	36	24	0.158	528
MZP 18 A R	MZP 18 A L	Tr 18x4	1	40	27	0.218	553
MZP 20 A R	MZP 20 A L	Tr 20x4	1	45	30	0.308	847
MZP 22 A R	MZP 22 A L	Tr 22x5	1	45	33	0.324	1010
MZP 24 A R	MZP 24 A L	Tr 24x5	1	50	36	0.440	1215
MZP 26 A R	MZP 26 A L	Tr 26x5	1	50	39	0.454	1440
MZP 28 A R	MZP 28 A L	Tr 28x5	1	60	42	0.747	1680
MZP 30 A R	MZP 30 A L	Tr 30x6	1	60	45	0.773	1908
MZP 32 A R	MZP 32 A L	Tr 32x6	1	60	48	0.790	2186
MZP 36 A R	MZP 36 A L	Tr 36x6	1	75	54	1.476	2800
MZP 40 A R	MZP 40 A L	Tr 40x7	1	80	60	1.826	3440
MZP 44 A R	MZP 44 A L	Tr 44x7	1	80	66	1.878	4200
MZP 50 A R	MZP 50 A L	Tr 50x8	1	90	75	2.680	5418
MZP 60 A R	MZP 60 A L	Tr 60x9	1	100	90	3.698	7847
MZP 70 A R	MZP 70 A L	Tr 70x10	1	110	105	4.884	10200
MZP 80 A R	MZP 80 A L	Tr 80x10	1	120	120	6.210	14137

(1) Total bearing surface between screw and nut teeth on plane perpendicular to axis.

We reserve the right to change sizes and features without notice.

Trapezoidal nut type HSN - Cylindrical bronze

Material: EN 1982 Cu Sn5 Zn5 Pb5-C – CC491K

Cylindrical bronze nut for movement with modest loads compared with FXN, HDL and HAL.

Good lubrication is recommended.

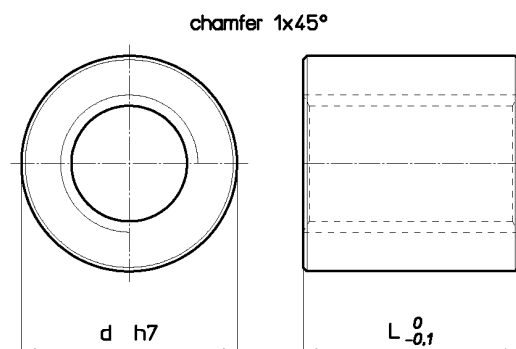

Nut Stock no. RIGHT	Nut Stock no. LEFT	Diameter x lead	Thread starts	d mm	L mm	Wt. kg/each	At mm ² (1)
HSN 12 A R	HSN 12 A L	Tr 12x3	1	36	36	0.302	594
HSN 14 A R	HSN 14 A L	Tr 14x4	1	36	36	0.290	677
HSN 16 A R	HSN 16 A L	Tr 16x4	1	36	36	0.276	792
HSN 16 B R	--	Tr 16x8 (P4)	2	36	36	0.276	792
HSN 18 A R	HSN 18 A L	Tr 18x4	1	36	36	0.259	905
HSN 20 A R	HSN 20 A L	Tr 20x4	1	40	40	0.354	1130
HSN 20 B R	--	Tr 20x8 (P4)	2	40	40	0.354	1130
HSN 22 A R	HSN 22 A L	Tr 22x5	1	40	40	0.33	1225
HSN 25 A R	HSN 25 A L	Tr 25x5	1	45	45	0.47	1590
HSN 25 B R	--	Tr 25x10 (P5)	2	45	45	0.47	1590
HSN 28 A R	HSN 28 A L	Tr 28x5	1	45	45	0.42	1800
HSN 28 B R	--	Tr 28x10 (P5)	2	45	45	0.42	1800
HSN 30 A R	HSN 30 A L	Tr 30x6	1	50	50	0.60	2120
HSN 30 B R	--	Tr 30x12 (P6)	2	50	50	0.60	2120
HSN 35 A R	HSN 35 A L	Tr 35x6	1	55	55	0.75	2764
HSN 40 A R	HSN 40 A L	Tr 40x7	1	60	60	0.92	3440
HSN 40 B R	--	Tr 40x14 (P7)	2	60	60	0.92	3440
HSN 45 A R	HSN 45 A L	Tr 45x8	1	65	65	1.10	4186
HSN 50 A R	HSN 50 A L	Tr 50x8	1	70	70	1.30	5057
HSN 55 A R	--	Tr 55x9	1	80	80	2.07	6345
HSN 60 A R	HSN 60 A L	Tr 60x9	1	80	80	1.75	6975

Trapezoidal nut type HBD - Cylindrical bronze

Material: EN 1982 Cu Sn7 Zn4 Pb7-C – CC493K

Cylindrical bronze nut for movement with modest loads compared with FXN, HDL and HAL. Good lubrication is recommended.

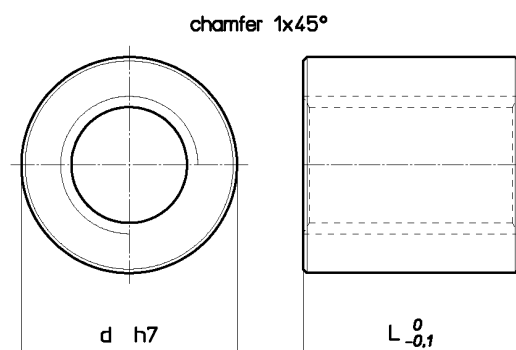

Nut Stock no. RIGHT	Nut Stock no. LEFT	Diameter x lead	Thread starts	d mm	L mm	Wt. kg/each	At mm ² (1)
HBD 10 T R	HBD 10 T L	Tr 10x2	1	22	20	0.058	200
HBD 10 A R	HBD 10 A L	Tr 10x3	1	22	20	0.057	320
HBD 12 A R	HBD 12 A L	Tr 12x3	1	26	24	0.094	396
HBD 12 B R	--	Tr 12x6 (P3)	2	26	24	0.094	396
HBD 14 R R	HBD 14 R L	Tr 14x3	1	30	28	0.146	526
HBD 14 A R	HBD 14 A L	Tr 14x4	1	30	28	0.146	526
HBD 16 A R	HBD 16 A L	Tr 16x4	1	36	32	0.245	704
HBD 18 A R	HBD 18 A L	Tr 18x4	1	40	36	0.337	905
HBD 20 A R	HBD 20 A L	Tr 20x4	1	45	40	0.476	1130
HBD 22 A R	HBD 22 A L	Tr 22x5	1	45	40	0.456	1225
HBD 24 A R	HBD 24 A L	Tr 24x5	1	50	48	0.680	1620
HBD 26 A R	HBD 26 A L	Tr 26x5	1	50	48	0.648	1770
HBD 28 A R	HBD 28 A L	Tr 28x5	1	60	60	1.237	2400
HBD 30 A R	HBD 30 A L	Tr 30x6	1	60	60	1.195	2544
HBD 32 A R	HBD 32 A L	Tr 32x6	1	60	60	1.145	2733
HBD 36 A R	HBD 36 A L	Tr 36x6	1	75	72	2.232	3732
HBD 40 A R	HBD 40 A L	Tr 40x7	1	80	80	2.823	4587
HBD 44 A R	HBD 44 A L	Tr 44x7	1	80	80	2.639	5090
HBD 50 A R	HBD 50 A L	Tr 50x8	1	90	100	4.142	7224
HBD 60 A R	HBD 60 A L	Tr 60x9	1	100	120	5.716	10462
HBD 70 A R	HBD 70 A L	Tr 70x10	1	110	140	7.548	10200
HBD 80 A R	HBD 80 A L	Tr 80x10	1	120	160	9.60	18850

(1) Total bearing surface between screw and nut teeth on plane perpendicular to axis.

Trapezoidal nut type HDA - Cylindrical stainless steel

Material: INOX A1 - AISI 303 – 1.4305

Nut of AISI 303 stainless steel especially suitable to withstand corrosive chemical agents

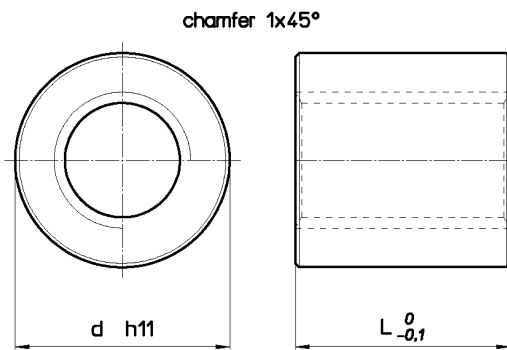

Nut Stock no. RIGHT	Nut Stock no. LEFT	Diameter x lead	Thread starts	d mm	L mm	Wt. kg/each	At mm ² (1)
HDA 12 A R	HDA 12 A L	Tr 12x3	1	26	18	0.060	297
HDA 14 A R	HDA 14 A L	Tr 14x4	1	30	21	0.095	395
HDA 16 A R	HDA 16 A L	Tr 16x4	1	36	24	0.157	528
HDA 20 A R	HDA 20 A L	Tr 20x4	1	45	30	0.305	847
HDA 24 A R	HDA 24 A L	Tr 24x5	1	50	36	0.436	1215
HDA 30 A R	HDA 30 A L	Tr 30x6	1	60	45	0.766	1908
HDA 36 A R	HDA 36 A L	Tr 36x6	1	75	54	1.462	2799
HDA 40 A R	HDA 40 A L	Tr 40x7	1	80	60	1.808	3440
HDA 50 A R	HDA 50 A L	Tr 50x8	1	90	75	2.653	5418

Trapezoidal nut type HBM - Cylindrical bronze

Material: EN 1982 Cu Sn12-C – CC483K

Cylindrical bronze nut for movement with modest loads compared with HDL and HAL.

Good lubrication is recommended.

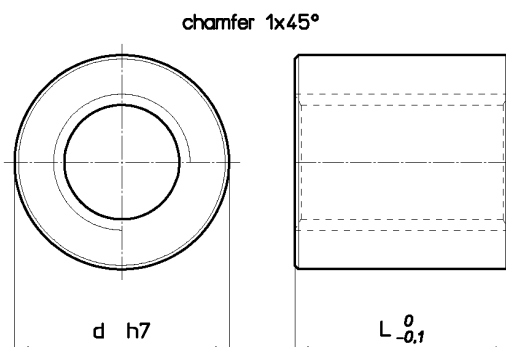

Nut Stock no. RIGHT	Nut Stock no. LEFT	Diameter x lead	Thread starts	d mm	L mm	Wt. kg/each	At mm ² (1)
HBM 10 A R	HBM 10 A L	Tr 10x3	1	20	20	0.044	320
HBM 12 A R	HBM 12 A L	Tr 12x3	1	24	25	0.078	412
HBM 14 A R	HBM 14 A L	Tr 14x4	1	24	25	0.071	470
HBM 16 A R	HBM 16 A L	Tr 16x4	1	28	30	0.118	660
HBM 18 A R	HBM 18 A L	Tr 18x4	1	34	35	0.214	880
HBM 20 A R	HBM 20 A L	Tr 20x4	1	38	40	0.304	1130
HBM 25 A R	HBM 25 A L	Tr 25x5	1	44	45	0.438	1590
HBM 30 A R	HBM 30 A L	Tr 30x6	1	48	50	0.532	2120
HBM 35 A R	HBM 35 A L	Tr 35x6	1	58	60	0.959	3015
HBM 36 A R	HBM 36 A L	Tr 36x6	1	58	60	0.923	3110
HBM 40 A R	HBM 40 A L	Tr 40x7	1	64	65	1.222	3727
HBM 45 A R	HBM 45 A L	Tr 45x8	1	68	80	1.579	5152
HBM 50 A R	HBM 50 A L	Tr 50x8	1	74	80	1.808	5780
HBM 55 A R	--	Tr 55x9	1	78	95	2.242	7535
HBM 60 A R	HBM 60 A L	Tr 60x9	1	84	95	2.536	8282
HBM 70 A R	HBM 70 A L	Tr 70x10	1	98	120	4.354	8742
HBM 80 A R	HBM 80 A L	Tr 80x10	1	108	120	4.892	14137

(1) Total bearing surface between screw and nut teeth on plane perpendicular to axis.

Trapezoidal nut type BIG - Cylindrical bronze

Material: EN 1982 Cu Sn12-C – CC483K

Large cylindrical nut with nonstandard pitches especially suitable for replacement.

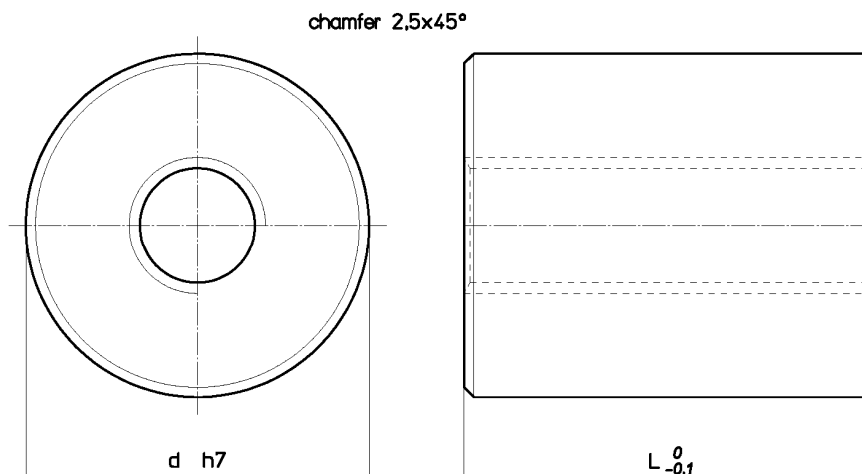

Nut Stock no. RIGHT	Nut Stock no. LEFT	Diameter x lead	Thread starts	d mm	L mm	Wt. kg/each	At mm ² (1)
BIG 20 A R	BIG 20 A L	Tr 20x4	1	78	60	2.43	1696
BIG 25 A R	BIG 25 A L	Tr 25x5	1	78	75	2.96	2650
BIG 30 R R	BIG 30 R L	Tr 30x3	1	78	90	3.30	3600
BIG 30 Q R	BIG 30 Q L	Tr 30x4	1	78	90	3.31	3560
BIG 30 P R	BIG 30 P L	Tr 30x5	1	78	90	3.32	3500
BIG 30 A R	BIG 30 A L	Tr 30x6	1	78	90	3.33	3435
BIG 35 R R	BIG 35 R L	Tr 35x3	1	88	105	4.85	5000
BIG 35 Q R	BIG 35 Q L	Tr 35x4	1	88	105	4.86	4900
BIG 35 P R	BIG 35 P L	Tr 35x5	1	88	105	4.87	4820
BIG 35 A R	BIG 35 A L	Tr 35x6	1	88	105	4.89	4750
BIG 40 R R	BIG 40 R L	Tr 40x3	1	98	120	6.80	6530
BIG 40 Q R	BIG 40 Q L	Tr 40x4	1	98	120	6.82	6447
BIG 40 P R	BIG 40 P L	Tr 40x5	1	98	120	6.83	6360
BIG 40 O R	BIG 40 O L	Tr 40x6	1	98	120	6.85	6277
BIG 40 A R	BIG 40 A L	Tr 40x7	1	98	120	6.87	6200
BIG 40 I R	--	Tr 40x10	1	98	120	6.91	6597
BIG 50 R R	BIG 50 R L	Tr 50x3	1	108	150	9.74	10300
BIG 50 Q R	BIG 50 Q L	Tr 50x4	1	108	150	9.77	10180
BIG 50 P R	BIG 50 P L	Tr 50x5	1	108	150	9.79	10070
BIG 50 O R	BIG 50 O L	Tr 50x6	1	108	150	9.82	9965
BIG 50 A R	BIG 50 A L	Tr 50x8	1	108	150	9.87	9750
BIG 50 I R	--	Tr 50x10	1	108	150	9.92	10600
BIG 60 O R	--	Tr 60x6	1	118	180	13.29	14500
BIG 60 N R	--	Tr 60x7	1	118	180	13.32	14380
BIG 60 A R	--	Tr 60x9	1	118	180	13.36	14130

(1) Total bearing surface between screw and nut teeth on plane perpendicular to axis.

Trapezoidal nut type CQA - Square steel

Material: EN 10277-3 11 S Mn Pb 37 – 1.0737

Used as fastening nut or for manual movement where load is negligible because steel-to-steel coupling used for movement under load tends to seize. The material used can be MIG welded only. Electrode welding is not recommended because of the lead.

chamfer 1x45°

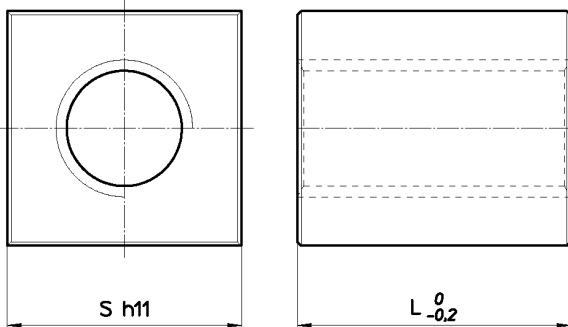

Nut Stock no. RIGHT	Nut Stock no. LEFT	Diameter x lead	Thread starts	S mm	L mm	Wt. kg/each	At mm ² (1)
CQA 10 T R	CQA 10 T L	Tr 10x2	1	17	15	0.027	150
CQA 12 A R	CQA 12 A L	Tr 12x3	1	25	30	0.123	739
CQA 14 A R	CQA 14 A L	Tr 14x4	1	30	35	0.211	658
CQA 16 A R	CQA 16 A L	Tr 16x4	1	30	35	0.199	770
CQA 18 A R	CQA 18 A L	Tr 18x4	1	35	45	0.353	1131
CQA 20 A R	CQA 20 A L	Tr 20x4	1	40	50	0.517	1412
CQA 25 A R	CQA 25 A L	Tr 25x5	1	45	55	0.683	1943
CQA 30 A R	CQA 30 A L	Tr 30x6	1	50	60	0.877	2544
CQA 35 A R	CQA 35 A L	Tr 35x6	1	60	70	1.494	3517
CQA 36 A R	CQA 36 A L	Tr 36x6	1	60	70	1.465	3630
CQA 40 A R	CQA 40 A L	Tr 40x7	1	60	70	1.347	4013
CQA 50 A R	CQA 50 A L	Tr 50x8	1	70	90	2.183	6502
CQA 60 A R	CQA 60 A L	Tr 60x9	1	80	100	2.990	8718

Trapezoidal nut type QOB - Square brass

Material: EN 12164 CW614N-M

Used as nut for movement of fairly small loads since the brass does not have great load bearing capability nor wear resistance.

chamfer 1x45°

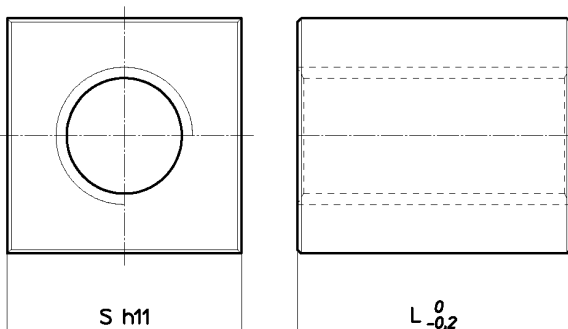

Nut Stock no. RIGHT	Nut Stock no. LEFT	Diameter x lead	Thread starts	S mm	L mm	Wt. kg/each	At mm ² (1)
QOB 10 A R	QOB 10 A L	Tr 10x3	1	25	20	0.094	320
QOB 12 A R	QOB 12 A L	Tr 12x3	1	25	25	0.110	411
QOB 14 R R	QOB 14 R L	Tr 14x3	1	25	20	0.076	658
QOB 14 A R	QOB 14 A L	Tr 14x4	1	30	35	0.224	658
QOB 16 A R	QOB 16 A L	Tr 16x4	1	30	35	0.212	770
QOB 18 A R	QOB 18 A L	Tr 18x4	1	35	45	0.379	1131
QOB 20 A R	QOB 20 A L	Tr 20x4	1	40	50	0.554	1412
QOB 25 A R	QOB 25 A L	Tr 25x5	1	45	55	0.735	1943
QOB 30 A R	QOB 30 A L	Tr 30x6	1	50	60	0.952	2544
QOB 35 A R	QOB 35 A L	Tr 35x6	1	60	70	1.617	3517
QOB 36 A R	QOB 36 A L	Tr 36x6	1	60	70	1.563	3630
QOB 40 A R	QOB 40 A L	Tr 40x7	1	60	70	1.465	4013

(1) Total bearing surface between screw and nut teeth on plane perpendicular to axis.

Trapezoidal nut type CQF – Steel square nut with holes

Material: EN 10277-3 11 S Mn Pb 37 – 1.0737

This nut is used as a fixing nut or for manual movements where the load is not important, because the steel to steel coupling used for moving under loads tends to seize.

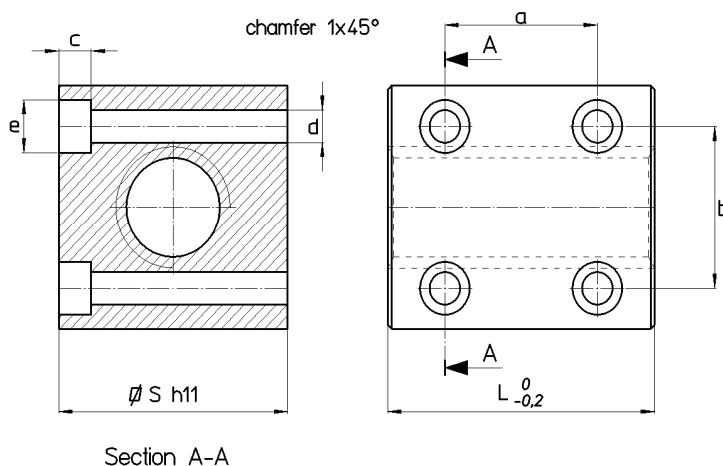

Nut Stock no. RIGHT	Nut Stock no. LEFT	Diameter x lead	Thread starts	S mm	L mm	a mm	b mm	c mm	d mm	e mm	Fixing allen screws UNI 5931	Wt. kg/each	At mm ² (1)
CQF 12 A R	CQF 12 A L	Tr 12x3	1	25	30	20	17	4.2	4	7	M4	0.123	739
CQF 14 A R	CQF 14 A L	Tr 14x4	1	30	35	24	20	5.2	5	9,5	M5	0.211	658
CQF 16 A R	CQF 16 A L	Tr 16x4	1	35	40	24	21	5.2	5	9,5	M5	0.199	770
CQF 18 A R	CQF 18 A L	Tr 18x4	1	35	45	26	24	6.5	6	10	M6	0.353	1131
CQF 20 A R	CQF 20 A L	Tr 20x4	1	40	50	38	28	6.5	6	10	M6	0.517	1412
CQF 25 A R	CQF 25 A L	Tr 25x5	1	45	55	40	33	6.5	6	10	M6	0.683	1943
CQF 30 A R	CQF 30 A L	Tr 30x6	1	50	60	48	38	6.5	6	10	M6	0.877	2544
CQF 35 A R	CQF 35 A L	Tr 35x6	1	60	70	55	45	8.5	8	13	M8	1.494	3517
CQF 40 A R	CQF 40 A L	Tr 40x7	1	60	70	55	49	8.5	8	9.9	M8 (3)	1.347	4013
CQF 50 A R	CQF 50 A L	Tr 50x8	1	70	90	70	60	8.5	8	9.9	M8 (3)	2.183	6502
CQF 60 A R	CQF 60 A L	Tr 60x9	1	80	100	80	69	8.5	8	9.9	M8 (3)	2.990	8718

(1) Total bearing surface between screw and nut teeth on plane perpendicular to axis.

(3) Special M8 fixing screw with a reduced head screw diameter.

Trapezoidal nut type QBF – Bronze square nut with holes

Material: EN 1982 Cu Sn12-C – CC483K

Tin bronze nut suitable for movements with modest loads. It is recommended for its fixing comfort and for its good wear resistance.

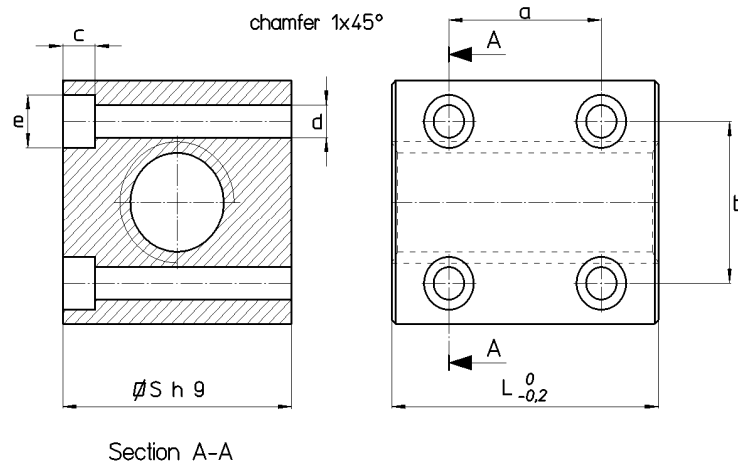

Nut Stock no. RIGHT	Nut Stock no. LEFT	Diameter x lead	Thread starts	S mm	L mm	a mm	b mm	c mm	d mm	e mm	Fixing allen screws UNI 5931	Wt. kg/each	At mm ² (1)
QBF 16 A R	QBF 16 A L	Tr 16x4	1	35	40	26	24	5.2	5	9,5	M5	0.340	770
QBF 20 A R	QBF 20 A L	Tr 20x4	1	40	50	38	28	6.5	6	10	M6	0.576	1412
QBF 25 A R	QBF 25 A L	Tr 25x5	1	45	55	40	33	6.5	6	10	M6	0.725	1943
QBF 30 A R	QBF 30 A L	Tr 30x6	1	50	60	49	38	6.5	6	10	M6	0.977	2544
QBF 40 A R	QBF 40 A L	Tr 40x7	1	60	75	55	49	8.5	8	9.9	M8 (3)	1.608	4013

(1) Total bearing surface between screw and nut teeth on plane perpendicular to axis.

(3) Special M8 fixing screw with a reduced head screw diameter.

Trapezoidal nut type FTN - Flanged bronze

Material: EN 1982 Cu Sn5 Zn5 Pb5-C – CC491K

Flanged bronze nut for movement of modest loads compared with FXN, HDL and HAL. Good lubrication is recommended. Flange dimensions make them fully interchangeable with FXN, HDL, HAL and FCS (total length and flange thickness change).

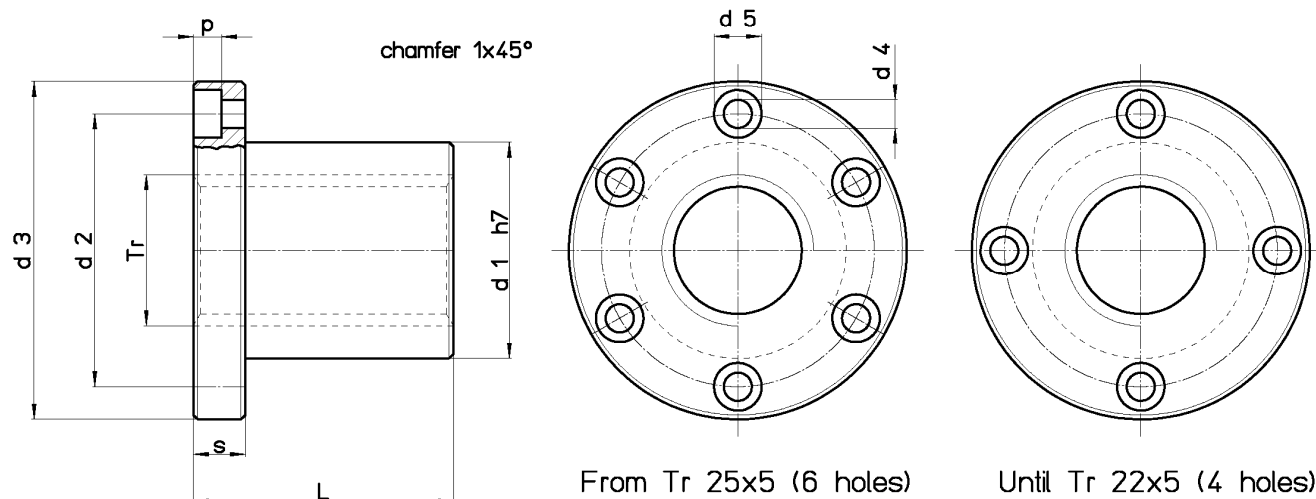

Nut Stock no. RIGHT	Nut Stock no. LEFT	Diameter x lead	Thread starts	d1 mm	d2 mm	d3 mm	d4 mm	d5 mm	p mm	L mm	s mm	no. screw holes	Fastening screws (class 8.8)	Wt. kg/each	At mm ² (1)
FTN 10 A R	FTN 10 A L	Tr 10x3	1	18	26	37	4.5	7.5	4.2	22	8	4	M4	0.088	294
FTN 12 A R	FTN 12 A L	Tr 12x3	1	18	26	37	4.5	7.5	4.2	22	8	4	M4	0.082	362
FTN 14 A R	FTN 14 A L	Tr 14x4	1	20	30	42	5.5	9.5	5.2	25	10	4	M5	0.123	470
FTN 16 A R	FTN 16 A L	Tr 16x4	1	22	32	45	5.5	9.5	5.2	30	10	4	M5	0.149	660
FTN 18 A R	FTN 18 A L	Tr 18x4	1	25	35	48	5.5	9.5	5.2	35	10	4	M5	0.188	880
FTN 20 A R	FTN 20 A L	Tr 20x4	1	30	40	52	5.5	9.5	5.2	40	10	4	M5	0.267	1130
FTN 22 A R	FTN 22 A L	Tr 22x5	1	30	40	52	5.5	9.5	5.2	40	10	4	M5	0.247	1225
FTN 25 A R	FTN 25 A L	Tr 25x5	1	35	48	62	6.5	11	6.5	45	12	6	M6	0.393	1590
FTN 28 A R	FTN 28 A L	Tr 28x5	1	40	53	68	6.5	11	6.5	50	12	6	M6	0.532	2000
FTN 30 R R	FTN 30 R L	Tr 30x3	1	40	53	68	6.5	11	6.5	50	12	6	M6	0.482	2238
FTN 30 Q R	FTN 30 Q L	Tr 30x4	1	40	53	68	6.5	11	6.5	50	12	6	M6	0.487	2200
FTN 30 P R	FTN 30 P L	Tr 30x5	1	40	53	68	6.5	11	6.5	50	12	6	M6	0.492	2160
FTN 30 A R	FTN 30 A L	Tr 30x6	1	40	53	68	6.5	11	6.5	50	12	6	M6	0.497	2120
FTN 35 R R	FTN 35 R L	Tr 35x3	1	50	63	78	8.5	14	8.5	60	15	6	M8	0.862	3160
FTN 35 Q R	FTN 35 Q L	Tr 35x4	1	50	63	78	8.5	14	8.5	60	15	6	M8	0.869	3110
FTN 35 P R	FTN 35 P L	Tr 35x5	1	50	63	78	8.5	14	8.5	60	15	6	M8	0.876	3060
FTN 35 A R	FTN 35 A L	Tr 35x6	1	50	63	78	8.5	14	8.5	60	15	6	M8	0.883	3015
FTN 35 M R	--	Tr 35x8	1	50	63	78	8.5	14	8.5	60	15	6	M8	0.898	2920
FTN 40 R R	FTN 40 R L	Tr 40x3	1	55	68	84	8.5	14	8.5	65	15	6	M8	1.030	3930
FTN 40 Q R	FTN 40 Q L	Tr 40x4	1	55	68	84	8.5	14	8.5	65	15	6	M8	1.039	3880
FTN 40 P R	FTN 40 P L	Tr 40x5	1	55	68	84	8.5	14	8.5	65	15	6	M8	1.048	3828
FTN 40 O R	FTN 40 O L	Tr 40x6	1	55	68	84	8.5	14	8.5	65	15	6	M8	1.057	3778
FTN 40 A R	FTN 40 A L	Tr 40x7	1	55	68	84	8.5	14	8.5	65	15	6	M8	1.066	3727
FTN 40 M R	--	Tr 40x8	1	55	68	84	8.5	14	8.5	65	15	6	M8	1.075	3675
FTN 45 A R	FTN 45 A L	Tr 45x8	1	55	72	90	8.5	14	8.5	65	15	6	M8	0.999	4186
FTN 50 R R	FTN 50 R L	Tr 50x3	1	65	80	100	10.5	17	10.5	80	20	6	M10	1.679	6095
FTN 50 Q R	FTN 50 Q L	Tr 50x4	1	65	80	100	10.5	17	10.5	80	20	6	M10	1.693	6030
FTN 50 P R	FTN 50 P L	Tr 50x5	1	65	80	100	10.5	17	10.5	80	20	6	M10	1.707	5970
FTN 50 O R	FTN 50 O L	Tr 50x6	1	65	80	100	10.5	17	10.5	80	20	6	M10	1.721	5905
FTN 50 A R	FTN 50 A L	Tr 50x8	1	65	80	100	10.5	17	10.5	80	20	6	M10	1.749	5780
FTN 55 A R	--	Tr 55x9	1	65	80	100	10.5	17	10.5	80	20	6	M10	1.475	6345
FTN 60 O R	FTN 60 O L	Tr 60x6	1	75	95	120	12.5	19	12.5	100	25	6	M12	2.865	8950
FTN 60 N R	FTN 60 N L	Tr 60x7	1	75	95	120	12.5	19	12.5	100	25	6	M12	2.886	8875
FTN 60 A R	FTN 60 A L	Tr 60x9	1	75	95	120	12.5	19	12.5	100	25	6	M12	2.927	8718

(1) Total bearing surface between screw and nut teeth on plane perpendicular to axis.

Trapezoidal nut type FXN - Flanged bronze

Material: EN 1982 Cu Sn12-C – CC483K

Tin bronze nut especially suitable for continuous movement with good wear resistance. Good lubrication is recommended. Flange dimensions make them fully interchangeable with FTN, HDL, HAL and FCS (total length and flange thickness change).

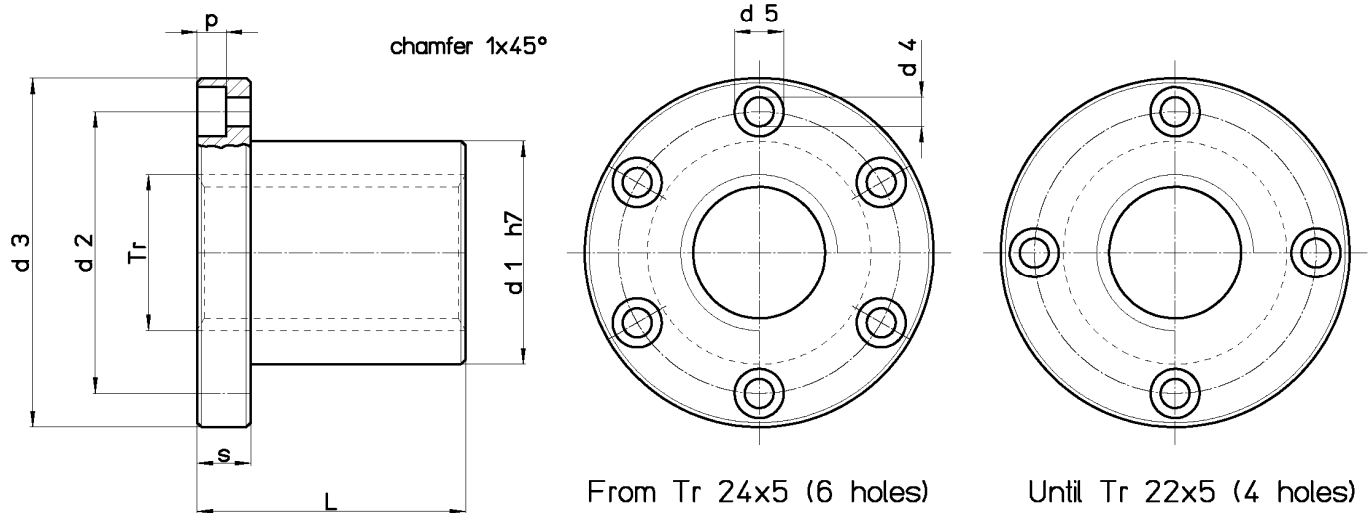

Nut Stock no. RIGHT	Nut Stock no. LEFT	Diameter x lead	Thread starts	d1 mm	d2 mm	d3 mm	d4 mm	d5 mm	p mm	L mm	s mm	no. screw holes	Fastening screws (class 8.8)	Wt. kg/each	At mm ² (1)
FXN 10 A R	FXN 10 A L	Tr 10x3	1	18	26	37	4.5	7.5	4.2	22	8	4	M4	0.088	294
FXN 12 A R	FXN 12 A L	Tr 12x3	1	18	26	37	4.5	7.5	4.2	22	8	4	M4	0.082	362
FXN 12 B R	--	Tr 12x6 (P3)	2	18	26	37	4.5	7.5	4.2	22	8	4	M4	0.082	362
FXN 14 A R	FXN 14 A L	Tr 14x4	1	20	30	42	5.5	9.5	5.2	25	10	4	M5	0.123	470
FXN 16 A R	FXN 16 A L	Tr 16x4	1	22	32	45	5.5	9.5	5.2	30	10	4	M5	0.149	660
FXN 16 B R	--	Tr 16x8 (P4)	2	22	32	45	5.5	9.5	5.2	30	10	4	M5	0.149	660
FXN 18 A R	FXN 18 A L	Tr 18x4	1	25	35	48	5.5	9.5	5.2	35	10	4	M5	0.188	880
FXN 20 A R	FXN 20 A L	Tr 20x4	1	30	40	52	5.5	9.5	5.2	40	10	4	M5	0.267	1130
FXN 20 B R	--	Tr 20x8 (P4)	2	30	40	52	5.5	9.5	5.2	40	10	4	M5	0.267	1130
FXN 20 D R	--	Tr 20x20 (P5)	4	30	40	52	5.5	9.5	5.2	40	10	4	M5	0.270	1100
FXN 22 A R	FXN 22 A L	Tr 22x5	1	30	40	52	5.5	9.5	5.2	40	10	4	M5	0.247	1225
FXN 24 A R	FXN 24 A L	Tr 24x5	1	35	48	62	6.5	11	6.5	45	12	6	M6	0.408	1520
FXN 25 A R	FXN 25 A L	Tr 25x5	1	35	48	62	6.5	11	6.5	45	12	6	M6	0.393	1590
FXN 25 B R	--	Tr 25x10 (P5)	2	35	48	62	6.5	11	6.5	45	12	6	M6	0.393	1590
FXN 25 E R	--	Tr 25x25 (P5)	5	35	48	62	6.5	11	6.5	45	12	6	M6	0.393	1590
FXN 26 A R	FXN 26 A L	Tr 26x5	1	35	48	62	6.5	11	6.5	45	12	6	M6	0.378	1660
FXN 28 A R	FXN 28 A L	Tr 28x5	1	40	53	68	6.5	11	6.5	50	12	6	M6	0.532	2000
FXN 28 B R	--	Tr 28x10 (P5)	2	40	53	68	6.5	11	6.5	50	12	6	M6	0.532	2000
FXN 30 A R	FXN 30 A L	Tr 30x6	1	40	53	68	6.5	11	6.5	50	12	6	M6	0.497	2120
FXN 30 B R	--	Tr 30x12 (P6)	2	40	53	68	6.5	11	6.5	50	12	6	M6	0.497	2120
FXN 30 F R	--	Tr 30x30 (P5)	6	40	53	68	6.5	11	6.5	50	12	6	M6	0.492	2590
FXN 32 A R	FXN 32 A L	Tr 32x6	1	40	53	68	6.5	11	6.5	50	12	6	M6	0.455	2277
FXN 35 A R	FXN 35 A L	Tr 35x6	1	50	63	78	8.5	14	8.5	60	15	6	M8	0.883	3015
FXN 36 A R	FXN 36 A L	Tr 36x6	1	50	63	78	8.5	14	8.5	60	15	6	M8	0.854	3110
FXN 40 A R	FXN 40 A L	Tr 40x7	1	55	68	84	8.5	14	8.5	65	15	6	M8	1.066	3727
FXN 40 B R	--	Tr 40x14 (P7)	2	55	68	84	8.5	14	8.5	65	15	6	M8	1.066	3727
FXN 40 E R	--	Tr 40x40 (P8)	5	55	68	84	8.5	14	8.5	65	15	6	M8	1.075	3675
FXN 44 A R	FXN 44 A L	Tr 44x7	1	55	72	90	8.5	14	8.5	65	15	6	M8	1.029	4135
FXN 45 A R	FXN 45 A L	Tr 45x8	1	55	72	90	8.5	14	8.5	65	15	6	M8	0.999	4186
FXN 50 A R	FXN 50 A L	Tr 50x8	1	65	80	100	10.5	17	10.5	80	20	6	M10	1.749	5780
FXN 55 A R	--	Tr 55x9	1	65	80	100	10.5	17	10.5	80	20	6	M10	1.475	6345
FXN 60 A R	FXN 60 A L	Tr 60x9	1	75	95	120	12.5	19	12.5	100	25	6	M12	2.927	8718

(1) Total bearing surface between screw and nut teeth on plane perpendicular to axis.

Trapezoidal nut type FMT - Flanged bronze

Material: EN 1982 Cu Sn12-C – CC483K

Tin bronze nut especially suitable for continuous movement with good wear resistance. Good lubrication is recommended.

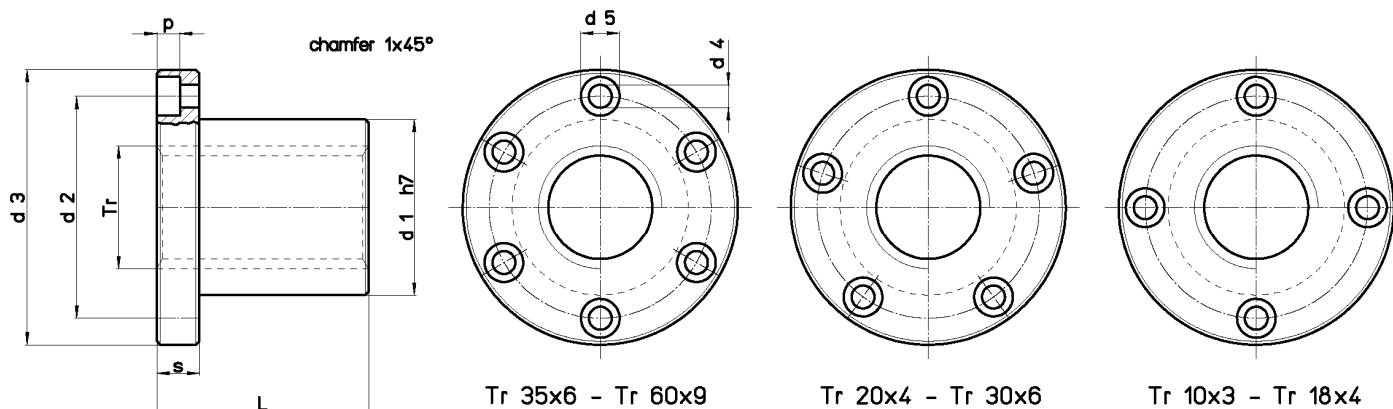

PAY ATTENTION TO THE NUMBER OF FASTENING SCREW HOLES SPECIFIED IN THE TABLE

Nut Stock no. RIGHT	Nut Stock no. LEFT	Diameter x lead	Thread starts	d1 mm	d2 mm	d3 mm	d4 mm	d5 mm	p mm	L mm	s mm	no. screw holes	Fastening screws (class 8.8)	Wt. kg/each	At mm ² (1)
FMT 10 A R	--	Tr 10x3	1	18	26	37	4.5	7.5	4.2	22	8	4	M4	0.088	294
FMT 12 A R	FMT 12 A L	Tr 12x3	1	18	26	37	4.5	7.5	4.2	22	8	4	M4	0.082	362
FMT 12 B R	--	Tr 12x6 (P3)	2	18	26	37	4.5	7.5	4.2	22	8	4	M4	0.082	362
FMT 14 A R	FMT 14 A L	Tr 14x4	1	20	30	42	5.5	9,5	5.2	25	10	4	M5	0.123	470
FMT 16 A R	FMT 16 A L	Tr 16x4	1	22	32	45	5.5	9,5	5.2	30	10	4	M5	0.149	660
FMT 16 B R	--	Tr 16x8 (P4)	2	22	32	45	5.5	9,5	5.2	30	10	4	M5	0.149	660
FMT 18 A R	FMT 18 A L	Tr 18x4	1	25	35	48	5.5	9,5	5.2	35	10	4	M5	0.188	880
FMT 20 A R	FMT 20 A L	Tr 20x4	1	30	40	52	5.5	9,5	5.2	40	10	5	M5	0.263	1130
FMT 20 B R	--	Tr 20x8 (P4)	2	30	40	52	5.5	9,5	5.2	40	10	5	M5	0.263	1130
FMT 22 A R	FMT 22 A L	Tr 22x5	1	30	40	52	5.5	9,5	5.2	40	10	5	M5	0.244	1225
FMT 25 A R	FMT 25 A L	Tr 25x5	1	35	48	62	6.5	11	6.5	45	12	5	M6	0.386	1590
FMT 25 B R	--	Tr 25x10 (P5)	2	35	48	62	6.5	11	6.5	45	12	5	M6	0.386	1590
FMT 28 A R	FMT 28 A L	Tr 28x5	1	40	53	68	6.5	11	6.5	50	12	5	M6	0.538	2000
FMT 30 A R	FMT 30 A L	Tr 30x6	1	40	53	68	6.5	11	6.5	50	12	5	M6	0.504	2120
FMT 30 B R	--	Tr 30x12 (P6)	2	40	53	68	6.5	11	6.5	50	12	5	M6	0.504	2120
FMT 35 A R	FMT 35 A L	Tr 35x6	1	50	63	78	6.5	11	6.5	60	12	6	M6	0.872	3015
FMT 36 A R	FMT 36 A L	Tr 36x6	1	50	63	78	6.5	11	6.5	60	12	6	M6	0.845	3110
FMT 40 A R	FMT 40 A L	Tr 40x7	1	55	68	84	6.5	11	6.5	65	12	6	M6	1.059	3727
FMT 40 B R	--	Tr 40x14 (P7)	2	55	68	84	6.5	11	6.5	65	12	6	M6	1.059	3727
FMT 45 A R	FMT 45 A L	Tr 45x8	1	55	72	90	8.5	14	8.5	65	15	6	M8	0.999	4186
FMT 50 A R	FMT 50 A L	Tr 50x8	1	65	80	100	8.5	14	8.5	80	15	6	M8	1.679	5780
FMT 55 A R	--	Tr 55x9	1	70	95	120	10.5	17	10.5	80	18	6	M10	2.325	6345
FMT 60 A R	FMT 60 A L	Tr 60x9	1	75	95	120	10.5	17	10.5	100	18	6	M10	2.701	8718

(1) Total bearing surface between screw and nut teeth on plane perpendicular to axis.

Trapezoidal nut type HDL - Flanged bronze

Material: EN 1982 Cu Sn12-C – CC483K

Flanged Bronze Nut of considerable length 3xTr suitable for operation under load with high loads and/or high movement speed. The special length of 3xTr greatly limits wear. Good lubrication is recommended.

Flange dimensions make them fully interchangeable with FTN, HDL, HAL and FCS (total length and flange thickness change).

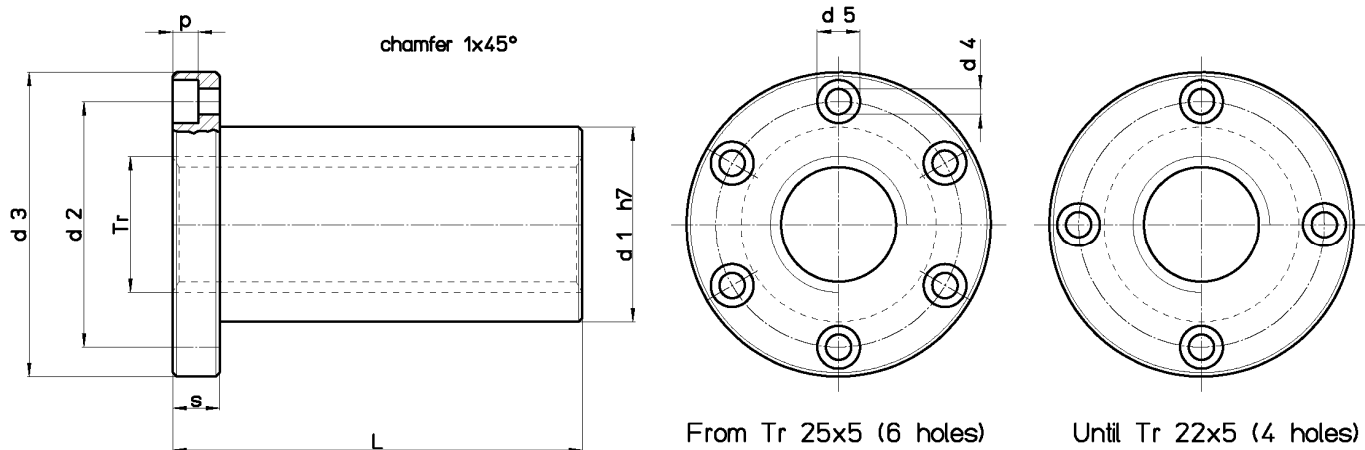

Nut Stock no. RIGHT	Nut Stock no. LEFT	Diameter x lead	Thread starts	d1 mm	d2 mm	d3 mm	d4 mm	d5 mm	p mm	L mm	s mm	no. screw holes	Fastening screws (class 8.8)	Wt. kg/each	At mm ² (1)
HDL 14 A R	HDL 14 A L	Tr 14x4	1	20	30	42	5.5	9,5	5.2	42	10	4	M5	0.151	790
HDL 16 A R	HDL 16 A L	Tr 16x4	1	22	32	45	5.5	9,5	5.2	48	10	4	M5	0.183	1056
HDL 16 B R	--	Tr 16x8 (P4)	2	22	32	45	5.5	9,5	5.2	48	10	4	M5	0.183	1056
HDL 18 A R	HDL 18 A L	Tr 18x4	1	25	35	48	5.5	9,5	5.2	54	10	4	M5	0.233	1356
HDL 20 A R	HDL 20 A L	Tr 20x4	1	30	40	52	5.5	9,5	5.2	60	12	4	M5	0.368	1696
HDL 20 B R	--	Tr 20x8 (P4)	2	30	40	52	5.5	9,5	5.2	60	12	4	M5	0.368	1696
HDL 22 A R	HDL 22 A L	Tr 22x5	1	30	40	52	5.5	9,5	5.2	60	12	4	M5	0.338	1838
HDL 25 A R	HDL 25 A L	Tr 25x5	1	35	48	62	6.5	11	6.5	75	15	6	M6	0.586	2650
HDL 25 B R	--	Tr 25x10 (P5)	2	35	48	62	6.5	11	6.5	75	15	6	M6	0.586	2650
HDL 25 E R	--	Tr 25x25 (P5)	5	35	48	62	6.5	11	6.5	75	15	6	M6	0.586	2650
HDL 28 A R	HDL 28 A L	Tr 28x5	1	40	53	68	6.5	11	6.5	90	18	6	M6	0.903	3600
HDL 28 B R	--	Tr 28x10 (P5)	2	40	53	68	6.5	11	6.5	90	18	6	M6	0.903	3600
HDL 30 A R	HDL 30 A L	Tr 30x6	1	40	53	68	6.5	11	6.5	90	18	6	M6	0.841	3816
HDL 30 B R	--	Tr 30x12 (P6)	2	40	53	68	6.5	11	6.5	90	18	6	M6	0.841	3816
HDL 30 R R	HDL 30 R L	Tr 30x3	1	40	53	68	6.5	11	6.5	90	18	6	M6	0.784	3816
HDL 32 A R	HDL 32 A L	Tr 32x6	1	40	53	68	6.5	11	6.5	90	18	6	M6	0.765	4100
HDL 35 A R	HDL 35 A L	Tr 35x6	1	50	63	78	8.5	14	8.5	105	20	6	M8	1.439	5277
HDL 40 A R	HDL 40 A L	Tr 40x7	1	55	68	84	8.5	14	8.5	120	25	6	M8	1.937	6880
HDL 40 I R	--	Tr 40x10	1	55	68	84	8.5	14	8.5	120	25	6	M8	1.986	6597
HDL 40 B R	--	Tr 40x14 (P7)	2	55	68	84	8.5	14	8.5	120	25	6	M8	1.937	6597
HDL 40 Q R	--	Tr 40x4	1	55	68	84	8.5	14	8.5	120	25	6	M8	1.929	6597
HDL 50 O R	--	Tr 50x6	1	65	80	100	10.5	17	10.5	150	30	6	M10	3.007	10840
HDL 50 A R	HDL 50 A L	Tr 50x8	1	65	80	100	10.5	17	10.5	150	30	6	M10	3.075	10840
HDL 50 I R	--	Tr 50x10	1	65	80	100	10.5	17	10.5	150	30	6	M10	3.127	10600
HDL 60 A R	HDL 60 A L	Tr 60x9	1	75	95	120	12.5	19	12.5	180	35	6	M12	4.797	15700

(1) Total bearing surface between screw and nut teeth on plane perpendicular to axis.

Trapezoidal nut type CBC - Flanged bronze

Material: EN 1982 Cu Sn12-C – CC483K

Flanged Bronze Nut suitable for movement with modest loads as compared with FXN, HDL and HAL.

Good lubrication is recommended.

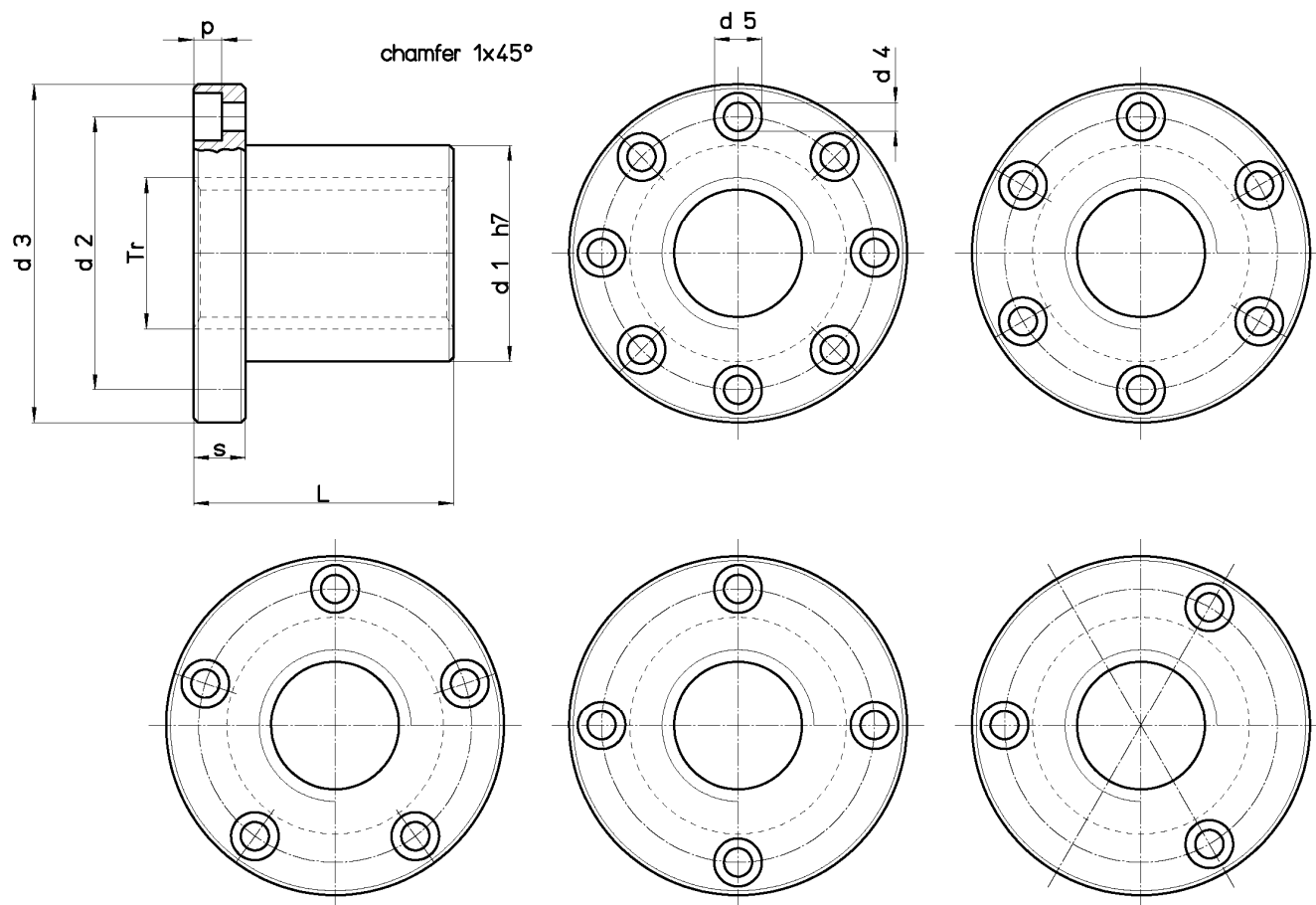

PAY ATTENTION TO THE NUMBER OF FASTENING SCREW HOLES SPECIFIED IN THE TABLE

Nut Stock no. RIGHT	Nut Stock no. LEFT	Diameter x lead	Thread starts	d1 mm	d2 mm	d3 mm	d4 mm	d5 mm	p mm	L mm	s mm	no. screw holes	Fastening screws (class 8.8)	Wt. kg/each	At mm ² (1)
CBC 10 A R	CBC 10 A L	Tr 10x3	1	16	24	32	4.5	7.5	4.2	20	8	3	M4	0.062	267
CBC 12 A R	CBC 12 A L	Tr 12x3	1	18	26	35	4.5	7.5	4.2	22	8	4	M4	0.074	362
CBC 14 A R	CBC 14 A L	Tr 14x4	1	20	30	40	5.5	9.5	5.2	25	10	4	M5	0.111	470
CBC 16 A R	CBC 16 A L	Tr 16x4	1	22	32	42	5.5	9.5	5.2	30	10	4	M5	0.131	660
CBC 18 A R	CBC 18 A L	Tr 18x4	1	25	35	45	5.5	9.5	5.2	35	10	4	M5	0.168	880
CBC 20 A R	CBC 20 A L	Tr 20x4	1	30	40	50	5.5	9.5	5.2	40	10	5	M5	0.248	1130
CBC 25 A R	CBC 25 A L	Tr 25x5	1	35	48	60	6.5	11	6.5	45	12	5	M6	0.380	1590
CBC 28 A R	CBC 28 A L	Tr 28x5	1	40	53	65	6.5	11	6.5	50	12	5	M6	0.505	2000
CBC 30 A R	CBC 30 A L	Tr 30x6	1	40	53	65	6.5	11	6.5	50	12	5	M6	0.470	2120
CBC 35 A R	CBC 35 A L	Tr 35x6	1	50	63	75	6.5	11	6.5	60	12	6	M6	0.815	3015
CBC 36 A R	CBC 36 A L	Tr 36x6	1	50	63	75	6.5	11	6.5	60	12	6	M6	0.786	3110
CBC 40 A R	CBC 40 A L	Tr 40x7	1	55	68	80	6.5	11	6.5	65	12	6	M6	0.971	3727
CBC 45 A R	CBC 45 A L	Tr 45x8	1	60	73	85	6.5	11	6.5	80	12	8	M6	1.254	5152
CBC 50 A R	CBC 50 A L	Tr 50x8	1	65	78	90	6.5	11	6.5	80	12	8	M6	1.372	5780
CBC 55 A R	--	Tr 55x9	1	70	85	100	8.5	14	8.5	95	15	6	M8	1.893	7534
CBC 60 A R	CBC 60 A L	Tr 60x9	1	75	90	105	8.5	14	8.5	95	15	6	M8	2.042	8282
CBC 70 A R	CBC 70 A L	Tr 70x10	1	90	105	120	8.5	14	8.5	120	18	8	M8	3.715	8742
CBC 80 A R	CBC 80 A L	Tr 80x10	1	100	115	130	8.5	14	8.5	120	18	8	M8	4.178	14137

(1) Total bearing surface between screw and nut teeth on plane perpendicular to axis.

Trapezoidal nut type FFR - Flanged bronze

Material: EN 1982 Cu Sn5 Zn5 Pb5-C – CC491K

Flanged bronze nut for movement for continuous movement with good wear resistance. Good lubrication is recommended.

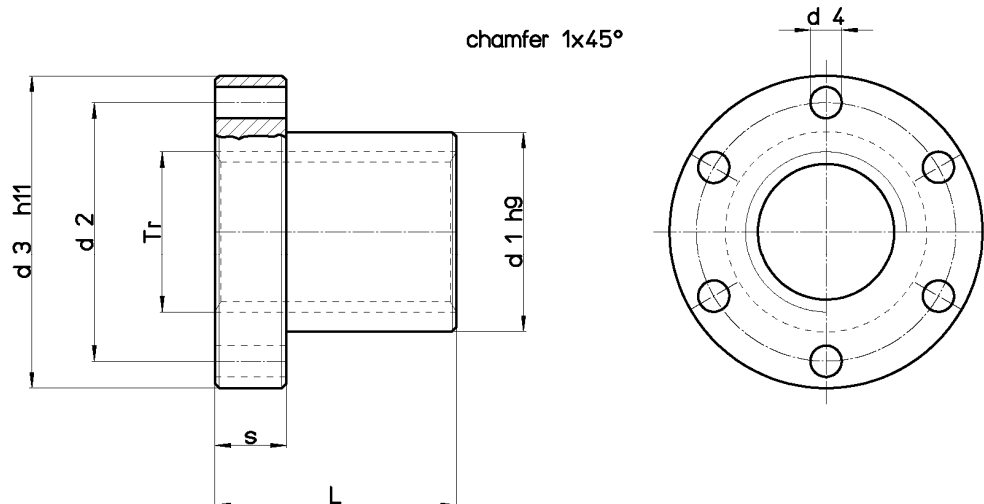

Nut Stock no. RIGHT	Nut Stock no. LEFT	Diameter x lead	Thread starts	d1 mm	d2 mm	d3 mm	d4 mm	L mm	S mm	no. screw holes	Viti di fissaggio (classe 8.8)	Wt. kg/each	At mm ² (1)
FFR 10 T R	FFR 10 T L	Tr 10x2	1	25	34	42	5	25	10	6	M6	0,164	250
FFR 10 J R	--	Tr 10x4 (P2)	2	25	34	42	5	25	10	6	M6	0,164	250
FFR 12 A R	FFR 12 A L	Tr 12x3	1	28	38	48	6	35	12	6	M6	0,276	400
FFR 12 B R	--	Tr 12x6 (P3)	2	28	38	48	6	35	12	6	M6	0,276	400
FFR 14 R R	FFR 14 R L	Tr 14x3	1	28	38	48	6	35	12	6	M6	0,272	460
FFR 14 B R	--	Tr 14x6 (P3)	2	28	38	48	6	35	12	6	M6	0,272	460
FFR 16 A R	FFR 16 A L	Tr 16x4	1	28	38	48	6	35	12	6	M6	0,260	530
FFR 16 B R	--	Tr 16x8 (P4)	2	28	38	48	6	35	12	6	M6	0,260	530
FFR 18 A R	FFR 18 A L	Tr 18x4	1	28	38	48	6	35	12	6	M6	0,247	610
FFR 18 B R	--	Tr 18x8 (P4)	2	28	38	48	6	35	12	6	M6	0,247	610
FFR 20 A R	FFR 20 A L	Tr 20x4	1	32	45	55	6,5	44	12	6	M6	0,370	870
FFR 20 B R	--	Tr 20x8 (P4)	2	32	45	55	6,5	44	12	6	M6	0,370	870
FFR 22 A R	FFR 22 A L	Tr 22x5	1	32	45	55	6,5	44	12	6	M6	0,360	1030
FFR 22 B R	--	Tr 22x10 (P5)	2	32	45	55	6,5	44	12	6	M6	0,360	1030
FFR 24 A R	FFR 24 A L	Tr 24x5	1	32	45	55	6,5	44	12	6	M6	0,337	1040
FFR 24 B R	--	Tr 24x10 (P5)	2	32	45	55	6,5	44	12	6	M6	0,337	1040
FFR 26 A R	FFR 26 A L	Tr 26x5	1	38	50	62	6,5	46	14	6	M6	0,516	1280
FFR 28 A R	FFR 28 A L	Tr 28x5	1	38	50	62	6,5	46	14	6	M6	0,472	1200
FFR 28 B R	--	Tr 28x10 (P5)	2	38	50	62	6,5	46	14	6	M6	0,472	1200
FFR 30 A R	FFR 30 A L	Tr 30x6	1	38	50	62	6,5	46	14	6	M6	0,421	1370
FFR 30 B R	--	Tr 30x12 (P6)	2	38	50	62	6,5	46	14	6	M6	0,421	1370
FFR 32 A R	FFR 32 A L	Tr 32x6	1	45	58	70	6,5	54	16	6	M6	0,779	1710
FFR 32 B R	--	Tr 32x12 (P6)	2	45	58	70	6,5	54	16	6	M6	0,779	1710
FFR 36 A R	FFR 36 A L	Tr 36x6	1	45	58	70	6,5	54	16	6	M6	0,694	1950
FFR 36 B R	--	Tr 36x12 (P6)	2	45	58	70	6,5	54	16	6	M6	0,694	1950
FFR 40 A R	FFR 40 A L	Tr 40x7	1	63	78	95	8,5	66	16	6	M6	1,788	2650
FFR 40 B R	--	Tr 40x14 (P7)	2	63	78	95	8,5	66	16	6	M6	1,788	2650
FFR 44 A R	FFR 44 A L	Tr 44x7	1	63	78	95	8,5	66	16	6	M6	1,657	2940
FFR 50 A R	FFR 50 A L	Tr 50x8	1	72	90	110	10,5	75	18	6	M6	2,500	4540
FFR 60 A R	FFR 60 A L	Tr 60x9	1	88	110	130	12,5	90	20	6	M6	4,260	5490
FFR 70 A R	FFR 70 A L	Tr 70x10	1	95	120	140	12,5	105	22	6	M6	5,303	7500

(1) Total bearing surface between screw and nut teeth on plane perpendicular to axis.

Trapezoidal nut type FHD - Flanged bronze

Material: EN 1982 Cu Sn12-C – CC483K

Tin bronze nut especially suitable for continuous movement with good wear resistance. Flange dimensions make them fully interchangeable with FTN, FXN, HDL, HAL and FCS (total length and flange thickness change). Good lubrication is recommended.

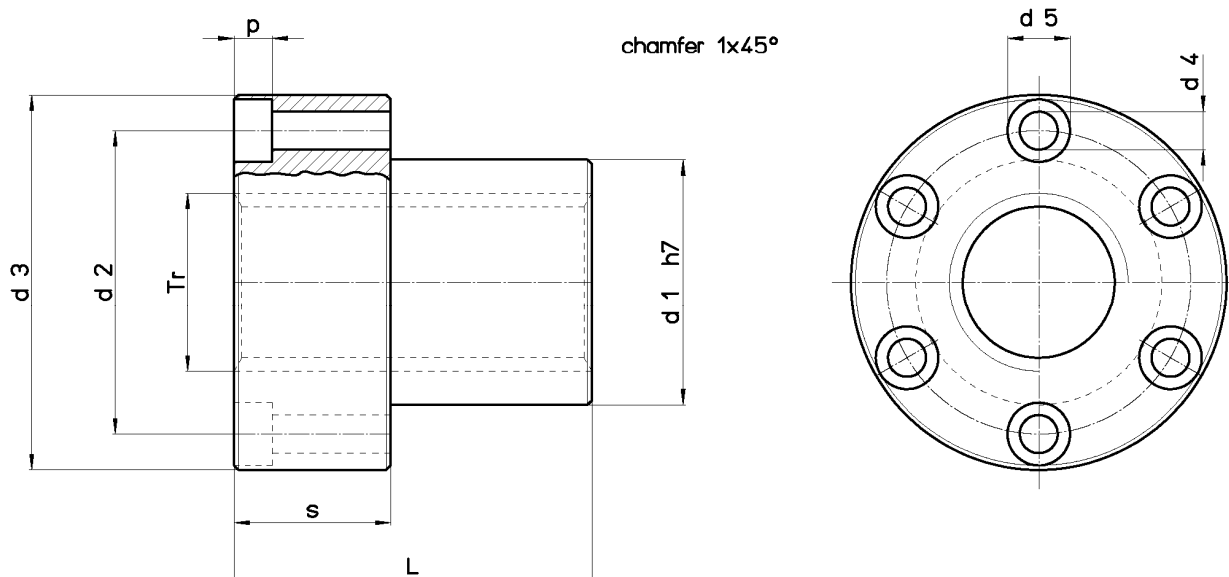

Nut Stock no. RIGHT	Nut Stock no. LEFT	Diameter x lead	Thread starts	d1 mm	d2 mm	d3 mm	d4 mm	d5 mm	p mm	L mm	s mm	no. screw holes	Fastening screws (class 8.8)	Wt. kg/each	At mm ² (1)
FHD 25 E R	--	Tr 25x25 (P5)	5	35	48	62	6.5	11	6.5	50	20	6	M6	0.581	1767
FHD 40 E R	--	Tr 40x40 (P8)	5	55	68	84	8.5	14	8.5	80	35	6	M8	1.849	4523

(1) Total bearing surface between screw and nut teeth on plane perpendicular to axis.

Trapezoidal nut type CDF - Double flanged bronze

Material: EN 1982 Cu Sn12-C – CC483K

Tin bronze nut especially suitable for continuous movement with good wear resistance. CDF nuts allow play adjustment between screw and nut. Working with preloaded nuts is only possible when using ball screws. Good lubrication is recommended.

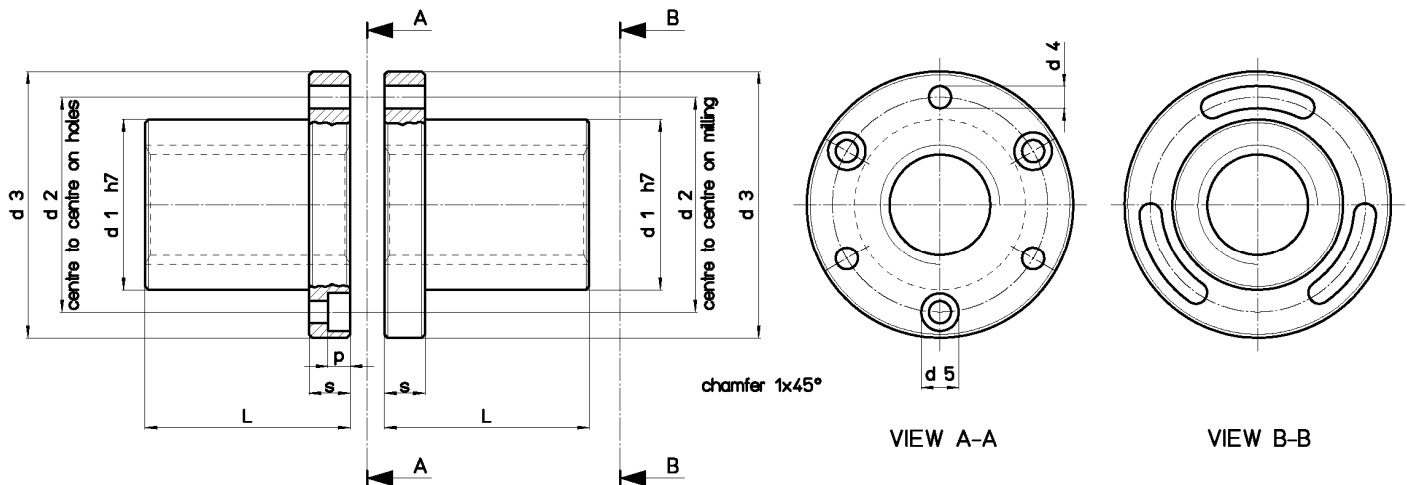

Nut Stock no. RIGHT	Nut Stock no. LEFT	Diameter x lead	Thread starts	d1 mm	d2 mm	d3 mm	d4 mm	d5 mm	p mm	L mm	s mm	no. screw holes	Fastening screws (class 8.8)	Wt. kg/each	At mm ² (1)
CDF 25 B R	--	Tr 25x10 (P5)	2	35	48	62	6.5	11	6.5	45	12	6	M6	0.786	1590
CDF 25 E R	--	Tr 25x25 (P5)	5	35	48	62	6.5	11	6.5	45	12	6	M6	0.786	1590
CDF 28 B R	--	Tr 28x10 (P5)	2	40	53	68	6.5	11	6.5	50	12	6	M6	1.064	2000

(1) Total bearing surface between screw and nut teeth on plane perpendicular to axis.

Installation Instructions:

- Nuts are supplied in pairs tied together. The pairs should be kept together when installed. Each nut pair has a notch cut on the external cylindrical part of the flange for correct installation. This notch should be identified immediately and referred to when installing as set forth below.
- Identify the nut to be fastened first; it is the nut with six holes in the flange and of which only three have seats for the cylindrical head screws with recessed hexagon (socket head screw). The second nut is the one with grooves on the flange and is to be fastened later.
- Fastening of the first nut to the structure which is to house it; fit the socket head screws in the three holes with seats for these screws. Insert the nut in its housing and fastened the three screws well; now the first nut is completely tightened in its seat.
- Fastening the second nut, the one which permits play adjustment. Identify the correct-assembly notch on both the nuts. Bring the second nut to the first nut flange-to-flange. Align the assembly notches on the flanges of the two nuts and fit in the three flange grooves the three screws which will be used for assembly of the second nut on the machine frame. Turn in the three screws just inserted in such a way that the two nuts rest against each other but do not tighten the screws yet. The nuts must rotate together.
- Screw assembly; assemble the screw by screwing it into the two nuts.
- Play adjustment. Rotate the second nut against the first nut so as to have the desired play and then tighten the three nuts locking the second nut to the frame.

Trapezoidal nut type HAL - Flanged aluminium bronze

Material: EN 1982 CuAl11Fe6Ni6-C – CC483K

Long flanged bronze nut 3xTr designed for operation with heavy loads thanks to the extreme hardness of aluminium bronze. The special 3xTr length greatly limits wear. The dimensions of the flange make them fully interchangeable with FTN, FXN, HDL and FCS (total length and flange thickness change). Generous and continuous lubrication of the HAL is recommended during use.

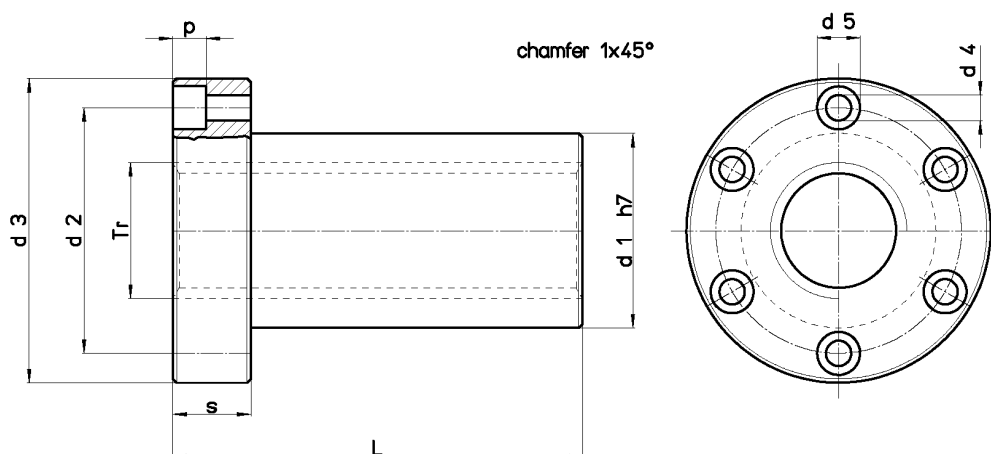

Nut Stock no. RIGHT	Nut Stock no. LEFT	Diameter x lead	Thread starts	d1 mm	d2 mm	d3 mm	d4 mm	d5 mm	p mm	L mm	s mm	no. screw holes	Fastening screws (class 8.8)	Wt. kg/each	At mm ² (1)
HAL 30 A R	HAL 30 A L	Tr 30x6	1	40	53	68	6.5	11	6.5	90	18	6	M6	0.712	3816
HAL 35 A R	--	Tr 35x6	1	50	63	78	8.5	14	8.5	105	20	6	M8	1.222	5277
HAL 40 A R	HAL 40 A L	Tr 40x7	1	55	68	84	8.5	14	8.5	120	25	6	M8	1.622	6880
HAL 40 I R	--	Tr 40x10	1	55	68	84	8.5	14	8.5	120	25	6	M8	1.684	6597
HAL 50 A R	HAL 50 A L	Tr 50x8	1	65	80	100	10.5	17	10.5	150	30	6	M10	2.590	10840
HAL 50 I R	--	Tr 50x10	1	65	80	100	10.5	17	10.5	150	30	6	M10	2.670	10600
HAL 60 A R	--	Tr 60x9	1	75	95	118	12.5	19	12.5	180	35	6	M12	3.982	15700

(1) Total bearing surface between screw and nut teeth on plane perpendicular to axis.

Trapezoidal nut type MES – Hexagonal in steel

Material: EN 10277-3 11SMnPb37 – 1.0737

Fixing nut very convenient thanks to its hexagonal shape. Not suitable for operations with high loads, because the coupling steel-steel tends to seize. This nuts can be MIG welded only. Electrode welding is not recommended because of the lead.

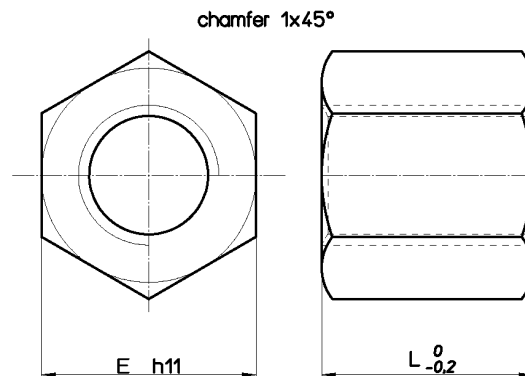

Nut Stock no. RIGHT	Nut Stock no. LEFT	Diameter x lead	Thread starts	E mm	L mm	Wt. kg/each	At mm ² (1)
MES 10 T R	MES 10 T L	Tr 10x2	1	17	15	0.023	150
MES 10 A R	MES 10 A L	Tr 10x3	1	17	15	0.021	240
MES 12 A R	MES 12 A L	Tr 12x3	1	19	18	0.027	296
MES 14 R R	MES 14 R L	Tr 14x3	1	22	21	0.044	395
MES 14 A R	MES 14 A L	Tr 14x4	1	22	21	0.044	395
MES 16 A R	MES 16 A L	Tr 16x4	1	27	24	0.082	528
MES 18 A R	MES 18 A L	Tr 18x4	1	27	27	0.084	553
MES 20 A R	MES 20 A L	Tr 20x4	1	30	30	0.114	847
MES 22 A R	MES 22 A L	Tr 22x5	1	30	33	0.112	1010
MES 24 A R	MES 24 A L	Tr 24x5	1	36	36	0.200	1215
MES 26 A R	MES 26 A L	Tr 26x5	1	36	39	0.193	1440
MES 28 A R	MES 28 A L	Tr 28x5	1	41	42	0.291	1680
MES 30 A R	MES 30 A L	Tr 30x6	1	46	45	0.420	1908
MES 32 A R	MES 32 A L	Tr 32x6	1	46	48	0.411	2186
MES 36 A R	MES 36 A L	Tr 36x6	1	55	54	0.706	2800
MES 40 A R	MES 40 A L	Tr 40x7	1	65	60	1.172	3440
MES 44 A R	MES 44 A L	Tr 44x7	1	65	66	1.159	4200
MES 50 A R	MES 50 A L	Tr 50x8	1	75	75	1.783	5418
MES 60 A R	MES 60 A L	Tr 60x9	1	90	90	3.087	7847
MES 70 A R	MES 70 A L	Tr 70x10	1	90	105	2.837	10200

(1) Total bearing surface between screw and nut teeth on plane perpendicular to axis.

Trapezoidal nut type FCS - Flanged self-lubricating plastic

Material: PA 6 + Mo S2 DIN 7728 + additives This Type of nut is made of a very wear-resistant perfectly self-lubricating plastic. It doesn't require any other lubrication as long as it is in use. The 3 x d length gives better load distribution and limits wear. The flange dimensions make them fully interchangeable with The FTN, FXN, HDL and HAL (total length and flange thickness are variable).

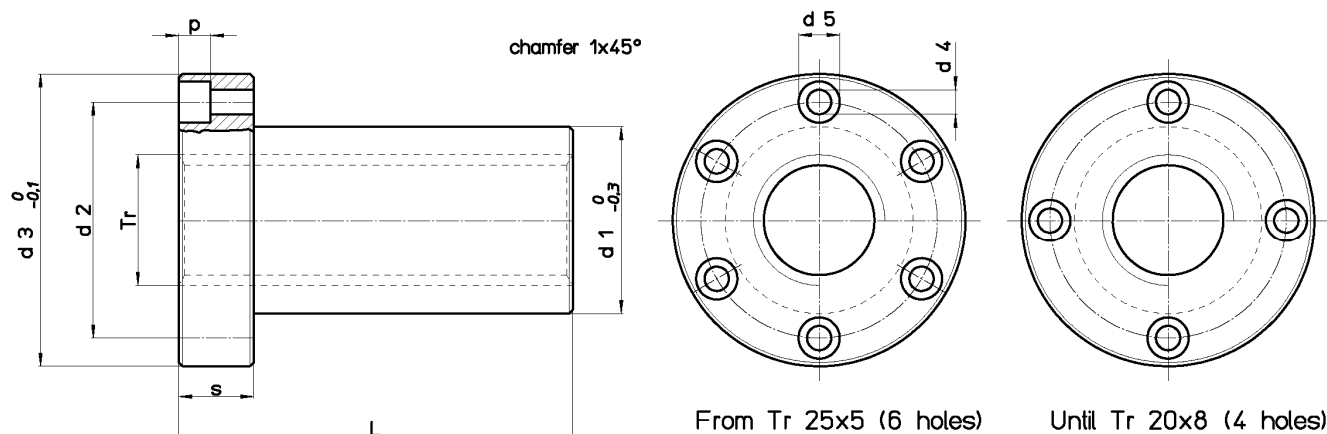

Nut Stock no. RIGHT	Nut Stock no. LEFT	Diameter x lead	Thread starts	d1 mm	d2 mm	d3 mm	d4 mm	d5 mm	p mm	L mm	s mm	no. screw holes	Fastening screws (class 8.8)	Wt. kg/each	At mm ² (1)
FCS 12 A R	FCS 12 A L	Tr 12x3	1	18	26	37	4.5	7.5	4.2	36	12	4	M4	0.016	594
FCS 16 A R	FCS 16 A L	Tr 16x4	1	22	32	45	5.5	9,5	5.2	48	16	4	M5	0.030	1056
FCS 20 A R	FCS 20 A L	Tr 20x4	1	30	40	52	5.5	9,5	5.2	60	20	4	M5	0.057	1696
FCS 20 B R	--	Tr 20x8 (P4)	2	30	40	52	5.5	9,5	5.2	60	20	4	M5	0.057	1696
FCS 25 A R	FCS 25 A L	Tr 25x5	1	35	48	62	6.5	11	6.5	75	25	6	M6	0.094	2650
FCS 28 A R	FCS 28 A L	Tr 28x5	1	40	53	68	6.5	11	6.5	90	30	6	M6	0.142	3600
FCS 28 B R	--	Tr 28x10 (P5)	2	40	53	68	6.5	11	6.5	90	30	6	M6	0.142	3600
FCS 30 A R	FCS 30 A L	Tr 30x6	1	40	53	68	6.5	11	6.5	90	30	6	M6	0.135	3816
FCS 35 A R	FCS 35 A L	Tr 35x6	1	50	63	78	8.5	14	8.5	105	35	6	M8	0.221	5277
FCS 40 A R	FCS 40 A L	Tr 40x7	1	55	68	84	8.5	14	8.5	120	40	6	M8	0.289	6880
FCS 40 I R	--	Tr 40x10	1	55	68	84	8.5	14	8.5	120	40	6	M8	0.252	6597
FCS 50 A R	FCS 50 A L	Tr 50x8	1	65	80	100	10.5	17	10.5	150	50	6	M10	0.476	10840

(1) Total bearing surface between screw and nut teeth on plane perpendicular to axis.

Trapezoidal nut type MPH - Cylindrical plastic

Material: PA 6 + Mo S2 DIN 7728 Highly wear resistant cylindrical plastic nut. Designed for low to medium loads. Lubricate MPH nuts occasionally with grease or oil to improve life. Do not use molybdenum disulfide MoS2 lubricants or graphite.

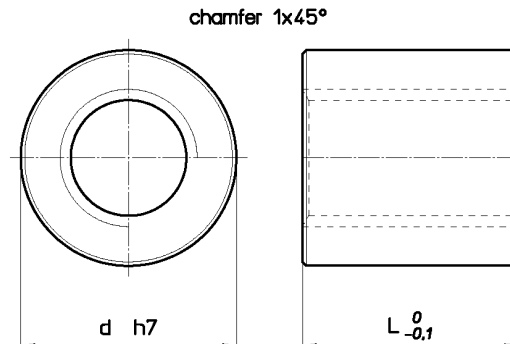

Nut Stock no. RIGHT	Nut Stock no. LEFT	Diameter x lead	Thread starts	d mm	L mm	Wt. kg/each	At mm ² (1)
MPH 12 A R	MPH 12 A L	Tr 12x3	1	26	24	0.012	396
MPH 16 A R	MPH 16 A L	Tr 16x4	1	36	32	0.030	704
MPH 20 A R	MPH 20 A L	Tr 20x4	1	45	40	0.060	1130
MPH 25 A R	MPH 25 A L	Tr 25x5	1	50	48	0.083	1696
MPH 28 A R	MPH 28 A L	Tr 28x5	1	60	60	0.154	2400
MPH 28 B R	--	Tr 28x10 (P5)	2	60	60	0.154	2400
MPH 30 A R	MPH 30 A L	Tr 30x6	1	60	60	0.150	2544
MPH 35 A R	MPH 35 A L	Tr 35x6	1	75	72	0.290	3618
MPH 40 A R	MPH 40 A L	Tr 40x7	1	80	80	0.355	4587
MPH 50 A R	MPH 50 A L	Tr 50x8	1	90	100	0.523	7225

(1) Total bearing surface between screw and nut teeth on plane perpendicular to axis.

Important note: These nuts are to be assembled only on our precision rolled screws which have suitable surface roughness and hardness. It is not possible to assemble FCS or MPH on screws made by machining. Be careful of the water-absorption of this material; it is not recommended for precision coupling due to the considerable dimensional variation resulting from relative humidity of the environment. Before selecting the plastic nut type, we recommend to consult our engineering department.

Trapezoidal screw specifications (also see pages for each screw type)

Diameter x lead	d 1 Major diameter tolerance 4 h min. max. mm		d 2 Effective or pitch dia. tolerance 7 e min. max. mm		d 3 Minor diameter tolerance 7 h min. max. mm		Thread starts	Lead angle	(1) Efficiency η $f=0.1$ $f=0.2$		(2) H 1 mm	I Moment of inertia mm ⁴
Tr 10 x 2	9.820	10.000	8.739	8.929	7.191	7.500	1	4°02'	0.41	0.26	1.0	131
Tr 10 x 3	9.764	10.000	8.203	8.415	6.150	6.500	1	6°25'	0.52	0.35	1.5	70
Tr 10 x 4 (P2)	9.820	10.000	8.739	8.929	7.191	7.500	2	8°03'	0.58	0.40	1.0	131
Tr 12 x 3	11.764	12.000	10.191	10.415	8.135	8.500	1	5°12'	0.47	0.31	1.5	215
Tr 12 x 6 (P3)	11.764	12.000	10.191	10.415	8.135	8.500	2	10°19'	0.63	0.46	1.5	215
Tr 14 x 3	13.764	14.000	12.191	12.415	10.135	10.500	1	4°22'	0.43	0.27	1.5	518
Tr 14 x 4	13.700	14.000	11.640	11.905	9.074	9.500	1	6°03'	0.51	0.34	2.0	333
Tr 14 x 6 (P3)	13.764	14.000	12.191	12.415	10.135	10.500	2	8°41'	0.59	0.42	1.5	518
Tr 16 x 4	15.700	16.000	13.640	13.905	11.074	11.500	1	5°12'	0.47	0.31	2.0	738
Tr 16 x 8 (P4)	15.700	16.000	13.640	13.905	11.074	11.500	2	10°19'	0.63	0.46	2.0	738
Tr 18 x 4	17.700	18.000	15.640	15.905	13.074	13.500	1	4°33'	0.44	0.28	2.0	1434
Tr 18 x 8 (P4)	17.700	18.000	15.640	15.905	13.074	13.500	2	9°02'	0.60	0.43	2.0	1434
Tr 20 x 4	19.700	20.000	17.640	17.905	15.074	15.500	1	4°03'	0.41	0.26	2.0	2534
Tr 20 x 8 (P4)	19.700	20.000	17.640	17.905	15.074	15.500	2	8°03'	0.58	0.40	2.0	2534
Tr 20 x 20 (P5)	19.665	20.000	17.114	17.394	14.044	14.500	4	20°00'	0.76	0.60	2.5	1910
Tr 22 x 5	21.665	22.000	19.114	19.394	16.044	16.500	1	4°40'	0.45	0.28	2.5	3232
Tr 22 x 10 (P5)	21.665	22.000	19.114	19.394	16.044	16.500	2	9°16'	0.61	0.43	2.5	3232
Tr 24 x 5	23.665	24.000	21.094	21.394	18.019	18.500	1	4°14'	0.42	0.27	2.5	5175
Tr 24 x 10 (P5)	23.665	24.000	21.094	21.394	18.019	18.500	2	8°25'	0.59	0.41	2.5	5175
Tr 25 x 3	24.764	25.000	23.165	23.415	21.103	21.500	1	2°20'	0.29	0.17	1.5	9735
Tr 25 x 5	24.665	25.000	22.094	22.394	19.019	19.500	1	4°03'	0.41	0.26	2.5	6423
Tr 25 x 10 (P5)	24.665	25.000	22.094	22.394	19.019	19.500	2	8°03'	0.58	0.40	2.5	6423
Tr 25 x 25 (P5)	24.665	25.000	22.094	22.394	19.019	19.500	5	19°30'	0.75	0.60	2.5	6423
Tr 26 x 5	25.665	26.000	23.094	23.394	20.019	20.500	1	3°52'	0.40	0.25	2.5	7884
Tr 26 x 10 (P5)	25.665	26.000	23.094	23.394	20.019	20.500	2	7°42'	0.57	0.39	2.5	7884
Tr 28 x 5	27.665	28.000	25.094	25.394	22.019	22.500	1	3°34'	0.38	0.23	2.5	11539
Tr 28 x 10 (P5)	27.665	28.000	25.094	25.394	22.019	22.500	2	7°07'	0.55	0.37	2.5	11539
Tr 30 x 3	29.764	30.000	28.165	28.415	26.103	26.500	1	1°55'	0.25	0.14	1.5	22900
Tr 30 x 4	29.700	30.000	27.640	27.905	25.074	25.500	1	2°36'	0.31	0.18	2.0	19400
Tr 30 x 5	29.665	30.000	27.094	27.394	24.019	24.500	1	3°19'	0.36	0.22	2.5	16340
Tr 30 x 6	29.625	30.000	26.547	26.882	22.463	23.000	1	4°03'	0.41	0.26	3.0	13650
Tr 30 x 12 (P6)	29.625	30.000	26.547	26.882	22.463	23.000	2	8°03'	0.58	0.40	3.0	13650
Tr 30 x 30 (P5)	29.665	30.000	27.094	27.394	24.019	24.500	6	19°09'	0.75	0.59	2.5	16340
Tr 32 x 6	31.625	32.000	28.547	28.882	24.463	25.000	1	3°46'	0.39	0.24	3.0	17580
Tr 32 x 12 (P6)	31.625	32.000	28.547	28.882	24.463	25.000	2	7°30'	0.56	0.38	3.0	17580
Tr 35 x 3	34.764	35.000	33.165	33.415	31.103	31.500	1	1°38'	0.22	0.12	1.5	46128
Tr 35 x 4	34.700	35.000	32.640	32.905	30.074	30.500	1	2°13'	0.28	0.16	2.0	40150
Tr 35 x 5	34.665	35.000	32.094	32.394	29.019	29.500	1	2°48'	0.33	0.19	2.5	34810
Tr 35 x 6	34.625	35.000	31.547	31.882	27.463	28.000	1	3°25'	0.37	0.23	3.0	30000
Tr 35 x 8	34.550	35.000	30.493	30.868	25.399	26.000	1	4°42'	0.45	0.29	4.0	21980
Tr 36 x 6	35.625	36.000	32.547	32.882	28.463	29.000	1	3°19'	0.36	0.22	3.0	34540
Tr 36 x 12 (P6)	35.625	36.000	32.547	32.882	28.463	29.000	2	6°36'	0.53	0.36	3.0	34540

(1) Useful effect for conversion of rotary movement to linear movement with friction coefficient $f=0.1$ and $f=0.2$.

(2) Radial support dimension between screw and nut teeth.

Trapezoidal screw specifications (also see pages for each screw type)

Diameter x lead	d 1 Major diameter tolerance 4 h min. max. mm		d 2 Effective or pitch dia. tolerance 7 e min. max. mm		d 3 Minor diameter tolerance 7 h min. max. mm		Thread starts	Lead angle	(1) Efficiency η $f=0.1$ $f=0.2$		(2) H 1 mm	I Moment of inertia mm ⁴
Tr 40 x 3	39.764	40.000	38.165	38.415	36.103	36.500	1	1°25'	0.20	0.11	1.5	83395
Tr 40 x 4	39.700	40.000	37.640	37.905	35.074	35.500	1	1°55'	0.25	0.14	2.0	74290
Tr 40 x 5	39.665	40.000	37.094	37.394	34.019	34.500	1	2°26'	0.30	0.17	2.5	65740
Tr 40 x 6	39.625	40.000	36.547	36.882	32.463	33.000	1	2°57'	0.34	0.20	3.0	57950
Tr 40 x 7	39.575	40.000	36.020	36.375	31.431	32.000	1	3°30'	0.38	0.23	3.5	51030
Tr 40 x 8	39.550	40.000	35.493	35.868	30.399	31.000	1	4°03'	0.41	0.26	4.0	44560
Tr 40 x 10	39.470	40.000	34.450	34.850	28.350	29.000	1	5°12'	0.47	0.31	5.0	31700
Tr 40 x 14 (P7)	39.575	40.000	36.020	36.375	31.431	32.000	2	6°58'	0.54	0.37	3.5	51030
Tr 40 x 40 (P8)	39.550	40.000	35.493	35.868	30.399	31.000	5	19°30'	0.75	0.60	4.0	44560
Tr 44 x 7	43.575	44.000	40.020	40.375	35.431	36.000	1	3°09'	0.35	0.21	3.5	81820
Tr 45 x 8	44.550	45.000	40.493	40.868	35.399	36.000	1	3°33'	0.38	0.23	4.0	81245
Tr 50 x 3	49.764	50.000	48.150	48.415	46.084	46.500	1	1°08'	0.16	0.09	1.5	121400
Tr 50 x 4	49.700	50.000	47.605	47.905	45.074	45.500	1	1°31'	0.21	0.12	2.0	202600
Tr 50 x 5	49.665	50.000	47.094	47.394	44.019	44.500	1	1°55'	0.25	0.14	2.5	184300
Tr 50 x 6	49.625	50.000	46.547	46.882	42.463	43.000	1	2°20'	0.29	0.17	3.0	167240
Tr 50 x 8	49.550	50.000	45.468	45.868	40.368	41.000	1	3°10'	0.35	0.21	4.0	136930
Tr 50 x 10	49.470	50.000	44.425	44.850	38.319	39.000	1	4°03'	0.41	0.26	5.0	105834
Tr 55 x 9	54.500	55.000	49.935	50.360	44.329	45.000	1	3°15'	0.36	0.22	4.5	189550
Tr 60 x 6	59.625	60.000	56.547	56.882	52.463	53.000	1	1°55'	0.25	0.14	3.0	386240
Tr 60 x 7	59.575	60.000	56.020	56.375	51.431	52.000	1	2°16'	0.28	0.16	3.5	343450
Tr 60 x 9	59.500	60.000	54.935	55.360	49.329	50.000	1	2°57'	0.34	0.20	4.5	302600
Tr 70 x 10	69.470	70.000	64.425	64.850	58.319	59.000	1	2°48'	0.33	0.19	5.0	587540
Tr 80 x 10	79.470	80.000	74.425	74.850	68.319	69.000	1	2°26'	0.30	0.17	5.0	1069390
Tr 90 x 12	89.400	90.000	83.335	83.830	76.246	77.000	1	2°36'	0.31	0.18	6.0	1658969
Tr 95 x 16	94.290	95.000	86.250	86.810	76.110	77.000	1	3°21'	0.37	0.22	8.0	1647164
Tr 100 x 12	99.400	100.000	93.330	93.830	86.215	87.000	1	2°19'	0.29	0.17	6.0	2712072
Tr 100 x 16	99.290	100.000	91.250	91.810	81.110	82.000	1	3°10'	0.35	0.21	8.0	2124553
Tr 120 x 14	119.330	120.000	112.290	112.820	103.157	104.00	1	2°16'	0.28	0.16	7.0	5558591
Tr 120 x 16	119.290	120.000	111.250	111.810	101.110	102.00	1	2°36'	0.31	0.16	8.0	5130342
Tr 140 x 14	139.330	140.000	132.290	132.820	123.157	124.00	1	1°55'	0.25	0.14	7.0	11292921
Tr 160 x 16	159.290	160.000	151.250	151.810	141.110	142.00	1	1°55'	0.25	0.14	8.0	19462609

(1) Useful effect for conversion of rotary movement to linear movement with friction coefficient $f=0.1$ and $f=0.2$.

(2) Radial support dimension between screw and nut teeth.

We reserve the right to change sizes and features without notice.

Trapezoidal nut specifications (also see pages for each nut type)

Diameter x lead	D 4 Major diameter tolerance H		D 2 Effective or pitch dia. tolerance 7 H		D 1 Minor diameter tolerance 4 H		Thread starts	Radial play between screw & nut		Axial play between screw & nut	
	min.	max.	min.	max.	min.	max.		min.	max.	min.	max.
	mm		mm		mm						
Tr 10 x 2	10.500		9.000	9.250	8.000	8.236	1	0.071	0.511	0.019	0.137
Tr 10 x 3	10.500		8.500	8.780	7.000	7.315	1	0.085	0.577	0.023	0.155
Tr 10 x 4 (P2)	10.500		9.000	9.250	8.000	8.236	2	0.071	0.511	0.019	0.137
Tr 12 x 3	12.500		10.500	10.800	9.000	9.315	1	0.085	0.609	0.023	0.163
Tr 12 x 6 (P3)	12.500		10.500	10.800	9.000	9.315	2	0.085	0.609	0.023	0.163
Tr 14 x 3	14.500		12.500	12.800	11.000	11.315	1	0.085	0.609	0.023	0.163
Tr 14 x 4	14.500		12.000	12.355	10.000	10.375	1	0.095	0.715	0.025	0.192
Tr 14 x 6 (P3)	14.500		12.500	12.800	11.000	11.315	2	0.085	0.609	0.023	0.163
Tr 16 x 4	16.500		14.000	14.355	12.000	12.375	1	0.095	0.715	0.025	0.192
Tr 16 x 8 (P4)	16.500		14.000	14.355	12.000	12.375	2	0.095	0.715	0.025	0.192
Tr 18 x 4	18.500		16.000	16.355	14.000	14.375	1	0.095	0.715	0.025	0.192
Tr 18 x 8 (P4)	18.500		16.000	16.355	14.000	14.375	2	0.095	0.715	0.025	0.192
Tr 20 x 4	20.500		18.000	18.355	16.000	16.375	1	0.095	0.715	0.025	0.192
Tr 20 x 8 (P4)	20.500		18.000	18.355	16.000	16.375	2	0.095	0.715	0.025	0.192
Tr 20 x 20 (P5)	20.500		17.500	17.875	15.000	15.450	4	0.106	0.761	0.028	0.204
Tr 22 x 5	22.500		19.500	19.875	17.000	17.450	1	0.106	0.761	0.028	0.204
Tr 22 x 10 (P5)	22.500		19.500	19.875	17.000	17.450	2	0.106	0.761	0.028	0.204
Tr 24 x 5	24.500		21.500	21.900	19.000	19.450	1	0.106	0.806	0.028	0.216
Tr 24 x 10 (P5)	24.500		21.500	21.900	19.000	19.450	2	0.106	0.806	0.028	0.216
Tr 25 x 3	25.500		23.500	23.835	22.000	22.315	1	0.085	0.670	0.023	0.180
Tr 25 x 5	25.500		22.500	22.900	20.000	20.450	1	0.106	0.806	0.028	0.216
Tr 25 x 10 (P5)	25.500		22.500	22.900	20.000	20.450	2	0.106	0.806	0.028	0.216
Tr 25 x 25 (P5)	25.500		22.500	22.900	20.000	20.450	5	0.106	0.806	0.028	0.216
Tr 26 x 5	26.500		23.500	23.900	21.000	21.450	1	0.106	0.806	0.028	0.216
Tr 26 x 10 (P5)	26.500		23.500	23.900	21.000	21.450	2	0.106	0.806	0.028	0.216
Tr 28 x 5	28.500		25.500	25.900	23.000	23.450	1	0.106	0.806	0.028	0.216
Tr 28 x 10 (P5)	28.500		25.500	25.900	23.000	23.450	2	0.106	0.806	0.028	0.216
Tr 30 x 3	30.500		28.500	28.835	27.000	27.315	1	0.085	0.670	0.023	0.180
Tr 30 x 4	30.500		28.000	28.855	26.000	26.375	1	0.095	1.215	0.025	0.326
Tr 30 x 5	30.500		27.500	27.900	25.000	25.450	1	0.106	0.806	0.028	0.216
Tr 30 x 6	31.000		27.000	27.450	24.000	24.500	1	0.118	0.903	0.032	0.242
Tr 30 x 12 (P6)	31.000		27.000	27.450	24.000	24.500	2	0.118	0.903	0.032	0.242
Tr 30 x 30 (P5)	30.500		27.500	27.900	25.000	25.450	6	0.106	0.806	0.028	0.216
Tr 32 x 6	33.000		29.000	29.450	26.000	26.500	1	0.118	0.903	0.032	0.242
Tr 32 x 12 (P6)	33.000		29.000	29.450	26.000	26.500	2	0.118	0.903	0.032	0.242
Tr 35 x 3	35.500		33.500	33.835	32.000	32.315	1	0.085	0.670	0.023	0.180
Tr 35 x 4	35.500		33.000	33.355	31.000	31.375	1	0.095	0.715	0.025	0.192
Tr 35 x 5	25.500		32.500	32.900	30.000	30.450	1	0.106	0.806	0.028	0.216
Tr 35 x 6	36.000		32.000	32.450	29.000	29.500	1	0.118	0.903	0.032	0.242
Tr 35 x 8	36.000		31.000	31.500	27.000	27.630	1	0.132	1.007	0.035	0.270
Tr 36 x 6	37.000		33.000	33.450	30.000	30.500	1	0.118	0.903	0.032	0.242
Tr 36 x 12 (P6)	37.000		33.000	33.450	30.000	30.500	2	0.118	0.903	0.032	0.242

Trapezoidal nut specifications (also see pages for each nut type)

Diameter x lead	D 4 Major diameter tolerance H		D 2 Effective or pitch dia. tolerance 7 H		D 1 Minor diameter tolerance 4 H		Thread starts	Radial play between screw & nut		Axial play between screw & nut	
	min.	max.	min.	max.	min.	max.		min.	max.	min.	max.
	mm		mm		mm						
Tr 40 x 3	40.500		38.500	38.835	37.000	37.315	1	0.085	0.670	0.023	0.180
Tr 40 x 4	40.500		38.000	38.355	36.000	36.375	1	0.095	0.715	0.025	0.192
Tr 40 x 5	40.500		37.500	37.900	35.000	35.450	1	0.106	0.806	0.028	0.216
Tr 40 x 6	41.000		37.000	37.450	34.000	34.500	1	0.118	0.903	0.032	0.242
Tr 40 x 7	41.000		36.500	36.975	33.000	33.560	1	0.125	0.955	0.033	0.256
Tr 40 x 8	41.000		36.000	36.500	32.000	32.630	1	0.132	1.007	0.035	0.270
Tr 40 x 10	41.000		35.000	35.530	30.000	30.710	1	0.150	1.080	0.040	0.289
Tr 40 x 14 (P7)	41.000		36.500	36.975	33.000	33.560	2	0.125	0.955	0.033	0.256
Tr 40 x 40 (P8)	41.000		36.000	36.500	32.000	32.630	5	0.132	1.007	0.035	0.270
Tr 44 x 7	45.000		40.500	40.975	37.000	37.560	1	0.125	0.955	0.033	0.256
Tr 45 x 8	46.000		41.000	41.500	37.000	37.630	1	0.132	1.007	0.035	0.270
Tr 50 x 3	50.500		48.500	48.855	47.000	47.315	1	0.085	0.705	0.023	0.189
Tr 50 x 4	50.500		48.000	48.400	46.000	46.375	1	0.095	0.795	0.025	0.213
Tr 50 x 5	50.500		47.500	47.900	45.000	45.450	1	0.106	0.806	0.028	0.216
Tr 50 x 6	51.000		47.000	47.450	44.000	44.500	1	0.118	0.903	0.032	0.242
Tr 50 x 8	51.000		46.000	46.530	42.000	42.630	1	0.132	1.062	0.035	0.285
Tr 50 x 10	51.000		45.000	45.560	40.000	40.710	1	0.150	1.135	0.040	0.304
Tr 55 x 9	56.000		50.500	51.060	46.000	46.670	1	0.140	1.125	0.038	0.301
Tr 60 x 6	61.000		57.000	57.450	54.000	54.500	1	0.118	0.903	0.032	0.242
Tr 60 x 7	61.000		56.500	56.975	53.000	53.560	1	0.125	0.955	0.033	0.256
Tr 60 x 9	61.000		55.500	56.060	51.000	51.670	1	0.140	1.125	0.038	0.301
Tr 70 x 10	71.000		65.000	65.560	60.000	60.710	1	0.150	1.135	0.040	0.304
Tr 80 x 10	81.000		75.000	75.560	70.000	70.710	1	0.150	1.135	0.040	0.304
Tr 90 x 12	91.000		84.000	84.630	78.000	78.800	1	0.170	1.295	0.046	0.347
Tr 95 x 16	97.000		87.000	87.750	79.000	80.000	1	0.190	1.500	0.051	0.402
Tr 100 x 12	101.000		94.000	94.670	88.000	88.800	1	0.170	1.340	0.046	0.359
Tr 100 x 16	102.000		92.000	92.750	84.000	85.000	1	0.190	1.500	0.051	0.402
Tr 120 x 14	122.000		113.000	113.710	106.00	106.900	1	0.180	1.420	0.048	0.380
Tr 120 x 16	122.000		112.000	112.750	104.00	105.000	1	0.190	1.500	0.051	0.402
Tr 140 x 14	142.000		133.000	133.710	126.00	126.900	1	0.180	1.420	0.048	0.380
Tr 160 x 16	162.000		152.000	152.750	144.00	145.000	1	0.190	1.500	0.051	0.402

General choice criteria

The choice between different types of screws and nuts available is generally carried out in light of the following considerations:

Choice of the screw

Working environment

For work environments where there are no particular corrosive or oxidizing agents C45 screws can be used. Where these conditions are not met, we recommend using stainless steel screws A2 or A4 which are particularly suitable in the following cases:

- With relative humidity of 70/80% and above.
- Immersed in water, even in sea water.
- In presence of particular corrosive agents such as chlorides. In case of highly corrosive agents please contact our Technical Department.
- Where, due to special construction requirements, components must not oxidise, for example in the food industry, where they are coupled with nuts HDA.
- Where screws can not be reached for lubrication. In particular, for lubricating “maintenance free” fittings they are coupled with plastic nuts.
- Where working temperature is relatively high because the stainless steel A2 and A4 feature a relatively high slag temperature due to the austenitic structure of the material.

Positioning accuracy

For positioning screws it is necessary to have the control of the error of the thread pitch. We provide customer screws with accuracy class 50 (50 µm/300 mm), 100 (100 µm/300 mm) and screws with class 200 (200 µm/300 mm) both in C45 and stainless steel A2. For standard carriage lead screws class 200 ones can be used.

Irreversibility

The complete irreversibility occurs with trapezoidal screw with helix angle $< 2^{\circ} 30'$.

In all other cases, torque may be transmitted to the drive gear in a still screw condition subject to a load on the nut (especially under vibration). However, a good irreversibility is present up to 5 or 6 degrees.

Choice of the nut

Working environment

Materials used for the production of nuts, available to customers, both in bronze and stainless steel 303, are resistant to standard oxidizing agents that occur in various applications of the trapezoidal screws/nuts. In the presence of corrosive agents please contact our Technical Department directly.

In applications where the presence of added lubricant (grease or oil) is not allowed we recommend the use of self lubricating plastic nuts.

The use of plastics is very constrained by the actual working conditions, therefore you may need to study the problem together with our technical department, and not rely on a choice based on intuition only. This is because plastics have sometimes excellent self-lubrication features, but have, at the same time, restrictions on the working temperature or moisture absorption problems as well as some mechanical properties that may not be suitable for the intended use. The preliminary study of the application, in such cases, is therefore required to achieve positive and satisfying results.

General sizing criteria

The actual sizing of a trapezoidal screw/nut couple must be done considering the following three points:

1. sizing to wear
2. sizing the critical bending load
3. sizing to the critical speed

In order to obtain a good working condition couple screw/nut, all three points above must be respected when sizing.

Sizing to wear

The coupling screw/nut system has been used for a long time in a number of applications for transforming rotary motion into linear motion. The total power applied to the screw (P_t) is return as usable power (P_u) to the nut. The ratio $P_u / P_t = \eta$ defines the efficiency of the system which depends, basically, on the friction coefficient between the contacting surfaces of the screw and the nut as well as the angle of helix of the thread. We are in the presence of sliding friction therefore we have some of the power that is converted into heat every time we make a movement. Just looking into this sliding friction parameters can be given to evaluate the functioning of the coupling. The criterion is to limit the contact surface pressure on the flank of the thread to allow a gentle glide between the two surfaces to avoid therefore heavy friction that erodes the material of the nut. The product $p \bullet V_{st}$ is also limited (p = contact surface pressure and V_{st} = sliding speed on the average diameter of the thread) in order to limit the power that is dissipated in heat. This helps to reduce the temperature of the surfaces in contact. This limitation is important to avoid lubricant damages if bronze nuts are used, whether using self-lubricating plastic nuts, without the addition of further oil or grease, temperature should be checked as at higher temperatures we will have minor values of the product $p \bullet V_{st}$ admissible.

Calculation of the contact surface pressure "p"

The contact surface pressure "p" is calculated using the following formula:

$$(1) \quad p = \frac{F}{A_t} \quad \begin{array}{l} F = \text{Axial Force [N]} \\ A_t = \text{Total bearing surface between the teeth of the nut and the screw in the plane perpendicular to the axis. [mm}^2\text{]} \end{array}$$

$$(2) \quad A_t = \pi \bullet d_m \bullet Z \bullet H_1 \quad \begin{array}{l} d_m = \text{mean diameter of the thread [mm]} \\ H_1 = \text{support radial size between the teeth of the screw and the nut [mm]} \\ Z = n^\circ \text{ of gripping teeth} \end{array} \quad Z = \frac{h_{\text{nut}} [\text{mm}]}{\left(\frac{\text{real-pitch} [\text{mm}]}{n^\circ \text{ starts}} \right)}$$

For standard nuts each A_t value has been reported into the tables.

Calculation of the sliding speed "Vst"

The sliding speed is calculated using one of the following formulas:

- if round speed of the screw has already been defined:

$$(3) \quad V_{st} = \frac{n \bullet P}{1000 \bullet \sin \alpha} \quad \begin{array}{l} n = \text{round speed per minute} \left[\frac{\text{round}}{\text{min.}} \right] \\ P = \text{thread pitch [mm]} \\ \alpha = \text{thread helix angle} \end{array}$$

- if we have already established at which speed the nut must move:

$$(4) \quad V_{st} = \frac{V_{tr}}{\sin \alpha} \quad \begin{array}{l} V_{st} = \text{sliding speed on mean diameter. [m/min]} \\ V_{tr} = \text{motion speed [m/min]} \\ \alpha = \text{thread helix angle} \end{array}$$

Please note that the screw round speed and the moving speed are bounded as follows:

$$(5) \quad n = \frac{1000 \bullet V_{tr}}{P} \quad \begin{array}{l} n = \text{round speed per minute} \\ V_{tr} = \text{motion speed [m/min]} \\ P = \text{thread pitch [mm]} \end{array}$$

Bronze nut sizing

As per the bronze nut, the study of the product $p \cdot V_{st}$ allows you to plot the graph N.1 where three areas are highlighted, each of which is characterized by certain working conditions that in terms of smoothness of the surfaces in contact allow us to make evaluations based on experimental results previously obtained. A good lubrication is always necessary, possibly with oil. With little or no lubrication working condition may vary greatly.

Graph N° 1 – Sliding condition for Bronze

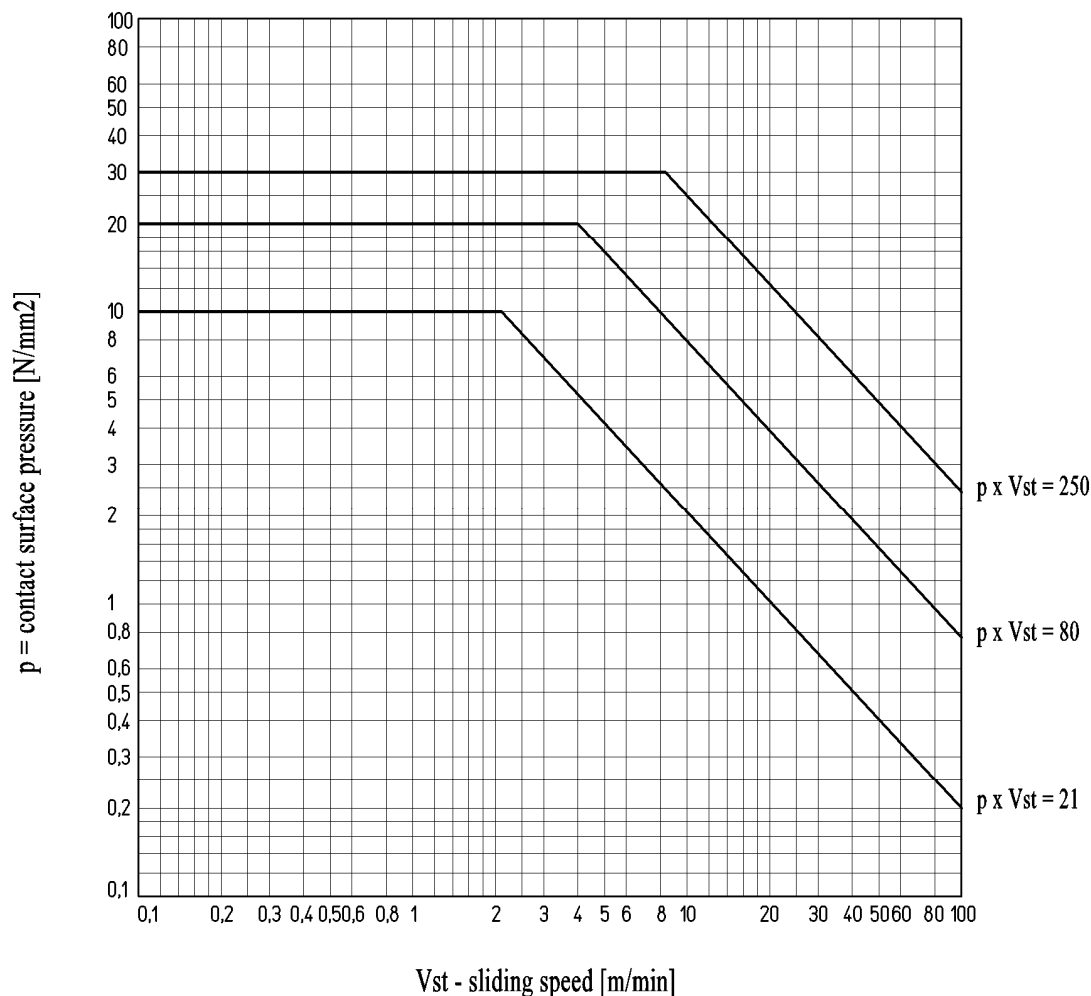

Area A : area A is enclosed by the limit $p \cdot V_{st} = 21$ [N/mm² • m/min]

In this area, the operation is in the best conditions.

"Continuous service" is possible as the amount of heat produced within these limits $p \cdot V_{st}$ is pretty low. Therefore the life of the nut is very good.

Area B : area B is enclosed by the limit $p \cdot V_{st} = 80$ [N/mm² • m/min]

In this area, the operation is in more severe conditions.

Sliding conditions are as such that a steady lubrication is required to contain the erosion of the bronze so you still have good values of the life of the nut. "Continuous service" is possible for limited period only as the amount of heat produced is as such to produce an overheating of the nut, also depending from the real amount of oil used as this, lubrication apart, helps reducing heat.

Life of the nut is however limited.

Area C : area C is enclosed by the limit $p \cdot V_{st} = 250$ [N/mm² • m/min]

In this area, the operation is in very heavy conditions.

With these values of $p \cdot V_{st}$ "continuous service" is certainly not possible. Even with good lubrication we face to a great overheating and a very quick nut wear off because the friction between the surfaces in contact is as such to cause a rapid corrosion of the nut.

General considerations for bronze nuts

In all three working conditions described, the bronze nut wear off is greatly affected by the real lubricating condition during operation. Giving acceptable reference values is therefore impossible during the project of the life of the nut. Pay particular attention to those applications where working room temperature is above 140/150°C, as such temperatures may damage the lubricant with consequent deterioration of operating conditions and lifetime. In such cases we recommend the use of lubricants designed to withstand high temperatures.

Safety factor for the forces of inertia " f_i "

During the sizing process we must also check that the inertia forces present during acceleration and deceleration are relatively low so that the value of $p \cdot V_{st}$ remains within the controlled limits. Whereas this calculation is difficult, in the presence of a non-uniform movement or under great variations, safety factors reported in Chart. N°1 must be considered.

Chart. N° 1: Safety factors with respect to the forces of inertia

Load Type	f_i
Loads with constant ramps of acc. / dec. controlled	from 1 to 0,5
Loads with constant start and stop at tear	from 0,5 to 0,33
Loads and speed greatly variable	from 0,33 to 0,25
Loads in presence of shocks and vibrations	from 0,25 to 0,17

The coefficient " f_i " is used to correct the value of the product " $(p \cdot V_{st})_{max}$ " derived from the graph N° 1, considering the maximum admissible sliding speed to the value of the contact surface pressure related to the real case in exam. Working "area" limits (A, B or C) must be considered.

To calculate $p \cdot V_{st}$ related to the case in exam admissible the following (6) must be used

$$(6) \quad p \cdot V_{st \text{ am}} = (p \cdot V_{st})_{max} \cdot f_i$$

Example of calculation with bronze nut

Size to wear a bronze nut which must operate in continuous service remaining within the maximum limit value of $p \cdot V_{st} = 21$ (Area A), with good lubrication.

Constant axial load without relevant variations, with forces of inertia limited by controlled ramps of acceleration/deceleration.

Axial load $F = 1200 \text{ N}$ (1 Kgf = 9,81N)
 Constant motion speed $V_{tr} = 2,8 \text{ m/min}$
 Evaluation of the product $p \cdot V_{st}$ using a nut FTN 30 AR (bronze flanged nut with thread Tr 30x6 1 start, right)

Contact surface pressure is calculated with (1) (see page 57)

$$p = \frac{F}{A_t} = \frac{1200 \text{ [N]}}{2120 \text{ [mm}^2\text{]}} = 0,57 \left[\frac{\text{N}}{\text{mm}^2} \right]$$

$F = \text{Axial Force [N]}$
 $A_t = \text{Total bearing surface between the teeth of the screws and the nuts in the plane perpendicular to the axis [mm}^2\text{]}$

The sliding speed is calculated with (4) (see page 57)

$$V_{st} = \frac{V_{tr}}{\sin \alpha} = \frac{2,8 \left[\frac{\text{m}}{\text{min}} \right]}{\sin 4^\circ 03'}$$

$$V_{st} \cong 39,6 \left[\frac{\text{m}}{\text{min}} \right]$$

$V_{tr} = \text{motion speed} \left[\frac{\text{m}}{\text{min}} \right]$
 $\alpha = \text{thread helix angle}$

The value of the product $p \cdot V_{st}$ is:

$$p \cdot V_{st} = 0,57 \left[\frac{\text{N}}{\text{mm}^2} \right] \cdot 39,6 \left[\frac{\text{m}}{\text{min}} \right] \cong 22,57 \left[\frac{\text{N}}{\text{mm}^2} \cdot \frac{\text{m}}{\text{min}} \right]$$

In order to remain within the continuous working conditions, corrected by the safety factor f_i from table N° 1, in this case $=0,77$, the maximum admissible value of $p \cdot V_{st}$ is (6) (see page 59)

$$p \cdot V_{st \text{ am}} = (p \cdot V_{st})_{\text{max}} \cdot f_i = 21 \cdot 0,77 \left[\frac{\text{N}}{\text{mm}^2} \cdot \frac{\text{m}}{\text{min}} \right]$$

$$p \cdot V_{st \text{ am}} = 16,15 \left[\frac{\text{N}}{\text{mm}^2} \cdot \frac{\text{m}}{\text{min}} \right]$$

As the maximum admissible value of the product $p \cdot V_{st}$ is lower than the value obtained with a nut FTN 30 AR, we shall try using a nut HDL 30 AR (bronze flanged nut with 3xTr length, Tr 30x6 thread, right)

The contact surface pressure is (1) (see page 57)

$$p = \frac{F}{A_t} = \frac{1200 \text{ [N]}}{2120 \text{ [mm}^2\text{]}} = 0,57 \left[\frac{\text{N}}{\text{mm}^2} \right]$$

$F = \text{Axial Force [N]}$
 $A_t = \text{Total bearing surface between the teeth of the screws and the nuts in the plane perpendicular to the axis [mm}^2\text{]}$

The sliding speed remains the same as the previous calculation

$$V_{st} = 39,6 \left[\frac{\text{m}}{\text{min}} \right]$$

The value of $p \cdot V_{st}$ is now:

$$p \cdot V_{st} = 0,31 \left[\frac{\text{N}}{\text{mm}^2} \right] \cdot 39,6 \left[\frac{\text{m}}{\text{min}} \right] \cong 12,28 \left[\frac{\text{N}}{\text{mm}^2} \cdot \frac{\text{m}}{\text{min}} \right]$$

The value obtained is now lower than the admissible one, therefore the HDL 30 AR is chosen.

Plastic Nuts sizing

In applications where silence is important or where lubrication is not allowed (grease or oil), self lubricating plastic nuts are recommended. The use of plastics is very constrained by the actual working conditions, therefore we do suggest studying the problem together with our technical office and not relying on a choice based only on intuition. This is because plastic materials have sometimes great features such as low friction and self-lubrication, but at the same time limitations caused by operating temperatures, hygroscopic problems, or some mechanical features that may not be suitable for the intended use. An advanced study of the application in this case is therefore required in order to obtain positive and satisfying results.

Regarding the plastic nuts, the study of the product p•Vst allows you to draw a chart which describes a curve that limits the values of p•Vst within which we have a gentle flow of the surfaces in contact with limited wearing of the nut and constant in time. Operating outside the limit drawn on the chart is not possible as in this case we would have a quick wearing of the nut following the surface erosion caused by the contact with the screw.

Cylindrical nut MPH

Graph N° 2 shows the limit of the product p•Vst of the cylindrical nut MPH. As this plastic is resistant to wear but not self-lubricant, drawing the limit curve relating to material used in dry conditions and material lubricated intermittently has been necessary.

Graph N° 2 – Sliding condition for nuts MPH

Test condition: - continuous operation - temperature 23°C – relative humidity approx 50%

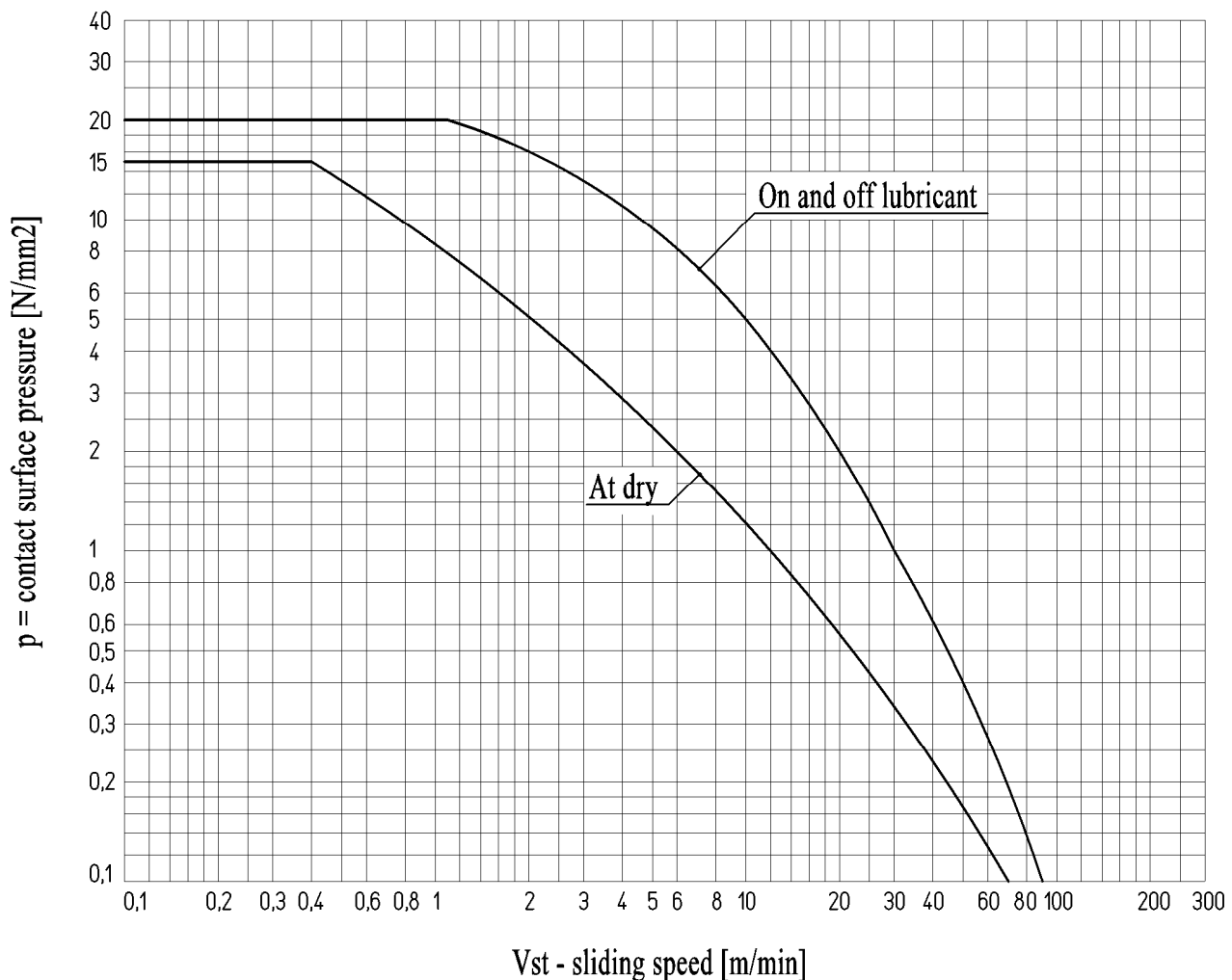

Self-lubricating plastic flanged nut with 3xTr length FCS

Graph N° 3 shows the limit of the product $p \cdot V_{st}$ of the nut FCS. The plastic used for the FCS features a strong resistance to wear and a complete self-lubricating property.

Prior using the FCS, please read what stated on page 50.

Graph N° 3
Sliding conditions for nuts in self-lubricating plastic FCS

Test conditions: - continuous operation - temperature 23°C – relative humidity approx 50% with no lubrication

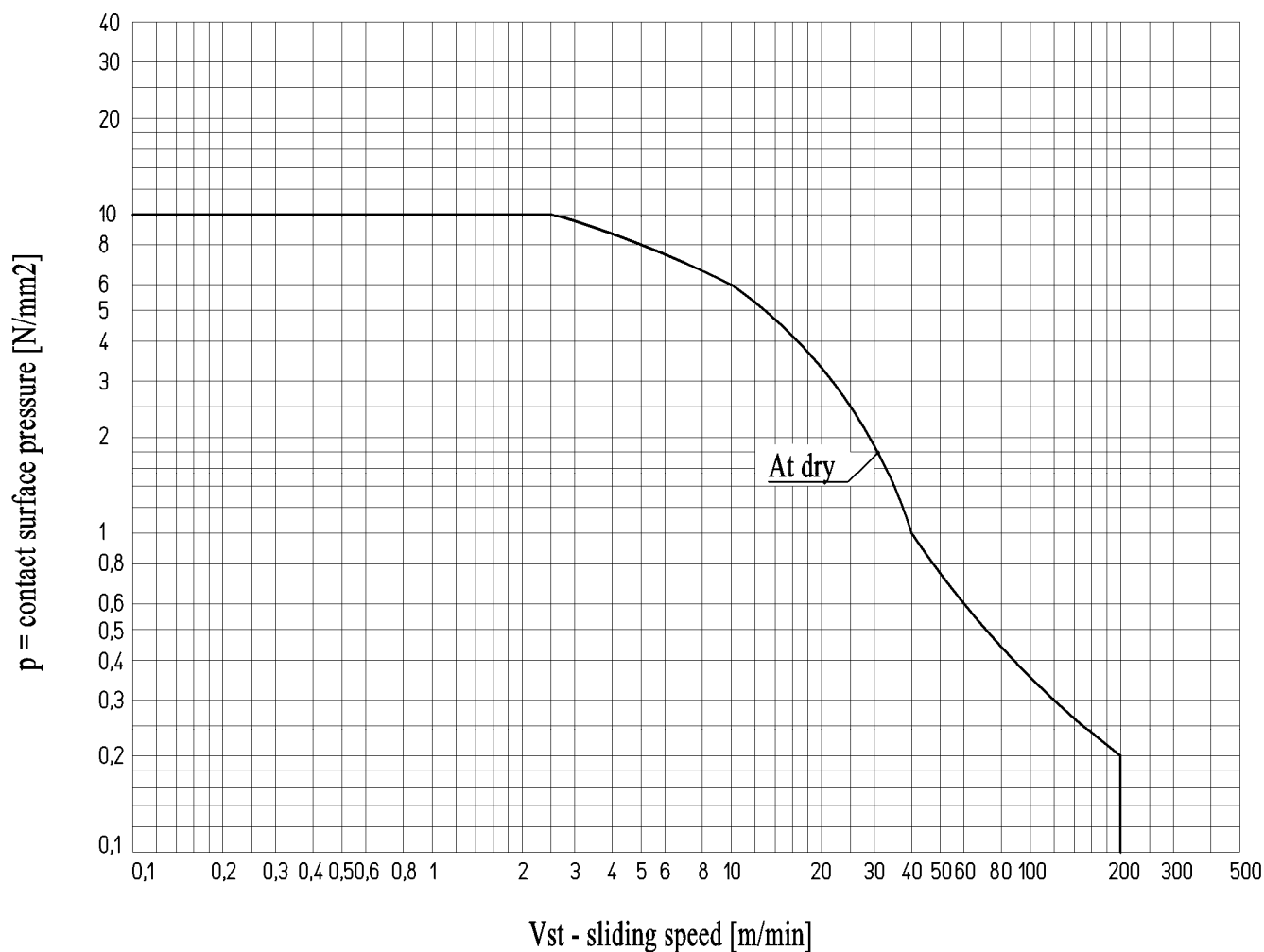

General considerations for plastic nuts

The use of plastics is very constrained by the actual working conditions, therefore you may need to study the problem together with our technical department, and not rely on a choice based on intuition only. This is because plastics have sometimes excellent self-lubrication features, but have, at the same time, restrictions on the working temperature or moisture absorption problems as well as some mechanical properties that may not be suitable for the intended use. The preliminary study of the application, in such cases, is therefore required to achieve positive and satisfying results.

Safety factor for the forces of inertia " f_i "

During the sizing process we must also check that the inertia forces present during acceleration and deceleration are relatively low so that the value of $p \cdot V_{st}$ remains within the controlled limits. Whereas this calculation is difficult, in the presence of a non-uniform movement or under great variations, safety factors reported in Chart. N°2 must be considered.

Chart. n° 2 : Safety factors with respect to the forces of inertia

Load type	f_i
Loads with constant ramps of acc. / dec. controlled	from 1 to 0,5
Loads with constant start and stop at tear	from 0,5 to 0,33
Loads and speed greatly variable	from 0,33 to 0,25
Loads in presence of shocks and vibrations	from 0,25 to 0,17

Correction factor for working environment temperature

Using plastic nuts MPH o FCS, the value of $p \cdot V_{st}$ admissible must be corrected in function of the working environment temperature. Plastic becomes softer at higher temperature and withstands minor load. At lower temperatures, it becomes harder and bears heavier loads. Correction factor " f_t " is shown in graph n° 4.

Graph N°4 - Correction factor " f_t " for nuts MPH and FCS

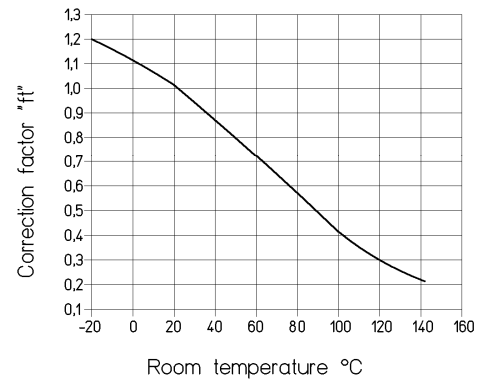

Correction factor dependent on intermittent use

Plastic nuts operating in on and off cycles for relatively short periods of time do not reach the limit of the maximum permissible temperature of the surface in contact with the screw. This temperature is a constraint that mainly contributes to limit the values of the product $p \cdot V_{st}$ in graphs N° 2 and N° 3 for the nuts MPH e FCS in continuous operation. The value of $p \cdot V_{st}$ admissible when operating in on and off cycles is higher than the value in continuous cycles. Deduce from graph N° 5 the value of the factor " f_c ". The curves of "x" represent the relationship between the downtime and the working time of the nut.

- 1 x represents downtime same as working time.
- 2 x represents downtime twice as much of the working time.
- 3 x represents downtime three times the working time.
- 4 x represents downtime four times the working time.

Find the working time value on the horizontal axis the working time value for the case in exam, climb vertically until intersecting the line of the relationship between the downtime and work time, then move horizontally and read the value of " f_c ".

Graph N°5 - Correction factor " f_c " for nuts MPH and FCS

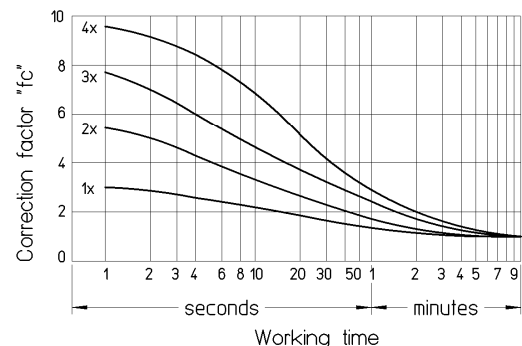

The values of the three coefficients " f_i ", " f_t ", " f_c " are used to correct the value of the product " $(p \cdot V_{st})$ " max read from graph N° 2 (for nut MPH) or graph N° 3 (for nut FCS), considering the maximum admissible sliding speed in "test conditions" relating to the contact surface pressure value of the real case in exam.

To calculate the admissible $p \cdot V_{st}$ of the case in exam we shall use (7) : $p \cdot V_{st} \text{ am} = (p \cdot V_{st})_{\text{max}} \cdot f_i \cdot f_t \cdot f_c$

Example of calculation with self-lubricating plastic nut

Size to wear a nut FCS flanged in self-lubricating plastic with 3xTr length which operate in the following conditions:

- Constant axial load with forces of inertia limited by controlled ramps of acceleration/deceleration of $F = 1750 \text{ N}$
- Moving speed = 10 m / min
- Working time = 20 sec. With downtime = 60 sec.
- Working environment temperature = 50°C
- No lubricant

The nut FCS is perfectly self-lubricating and therefore suitable to operate in the considered conditions.

We choose a nut which is available among those that may be compatible with the dimensions of the motion system to be realized. Then we verify that the value of the product $p \cdot V_{st}$ is lower than the admissible value of $p \cdot V_{st}$ as per the graph N° 3 and then correct it with the coefficients " f_i ", " f_t " and " f_c " from the chart N° 2 and graphs N° 4 and 5.

We choose the FCS40AR (flanged nut in self-lubricating plastic with 3xTr length, Tr 40x7 right threaded)

We calculate the contact surface pressure with (1)

$$p = \frac{F}{A_t} = \frac{1750 \text{ [N]}}{6880 \text{ [mm}^2\text{]}}$$

$F = \text{Axial Force [N]}$
 $A_t = \text{Total bearing surface between the teeth of the screws and the nuts in the plane perpendicular to the axis [mm}^2\text{]}$

$$p = 0,25 \left[\frac{\text{N}}{\text{mm}^2} \right]$$

The sliding speed is calculated with (4)

$$V_{st} = \frac{V_{tr}}{\sin \alpha} = \frac{10 \left[\frac{\text{m}}{\text{min}} \right]}{\sin 3^\circ 30'}$$

$V_{tr} = \text{Motion Speed} \left[\frac{\text{m}}{\text{min}} \right]$
 $\alpha = \text{thread helix angle}$

$$V_{st} \cong 164 \left[\frac{\text{m}}{\text{min}} \right]$$

The value of the product $p \cdot V_{st}$ is:

$$p \cdot V_{st} = 0,25 \left[\text{N/mm}^2 \right] \cdot 164 \left[\frac{\text{m}}{\text{min}} \right] \cong 41 \left[\frac{\text{N}}{\text{mm}^2} \cdot \frac{\text{m}}{\text{min}} \right]$$

Now we calculate the admissible value of the product $p \cdot V_{st}$ in the conditions in exam.

From the graph N° 3 we see that in continuous working conditions at 23°C with $p = 0,25 \text{ [N/mm}^2\text{]}$ the admissible value of V_{st} is $\cong 140 \text{ [m/min]}$

$$\text{i.e. } (p \cdot V_{st})_{\max} = 0,25 \cdot 140 = 35 \left[\frac{\text{N}}{\text{mm}^2} \cdot \frac{\text{m}}{\text{min}} \right]$$

- From graph N° 2 we read the value of the coefficient " f_i ". In our case " f_i " may be = $0,75$.
- From graph N° 4 we read the value of the coefficient " f_t ". In our case, in the working environment temperature of 50°C we may assume " f_t " = $0,8$
- From graph N° 5 we read the value of the coefficient " f_c ". In our case with working time of 20 sec. and downtime of 60 sec. , therefore

$$\frac{\text{downtime}}{\text{working time}} = 3 \text{ (curve 3x)} \quad \text{we assume "f}_c\text{" = } 3,7$$

The maximum admissible value of the product $p \cdot V_{st}$ in our case is (7):

$$p \cdot V_{st \text{ am}} = (p \cdot V_{st})_{\max} \cdot f_i \cdot f_t \cdot f_c = 35 \left[\frac{\text{N}}{\text{mm}^2} \cdot \frac{\text{m}}{\text{min}} \right] \cdot 0,75 \cdot 0,8 \cdot 3,7 = 77,7 \left[\frac{\text{N}}{\text{mm}^2} \cdot \frac{\text{m}}{\text{min}} \right]$$

As the value of the product $p \cdot V_{st}$ in this case is lower than the admissible value, the nut FCS 40 AR may be used for this motion.

Lifetime of the plastic nut

Using the experimental values it is possible to give an indication of the lifetime a plastic nut may have. The parameters that affect the life of a plastic nut are as follows:

- Value of the contact surface pressure p [N/mm^2]
- Value of the sliding speed V_{st} [m/min]
- Constant of the resistance to the wear of the plastic in exam derived from experimental tests k $\left[\frac{\text{mm}^3 \cdot \text{min}}{\text{N} \cdot \text{m} \cdot \text{hrs}} \right]$
- Correction factor f_c of the on and off cycle.

All data shown below are for coupling of plastic nuts with our precision rolled screws as we guarantee a surface roughness less than $1 \mu\text{m Ra}$.

Coupling plastic nuts with lathed screws is not possible.

The following calculations and considerations are for screws working at a temperature of approx $20/25^\circ\text{C}$ with relative humidity from 30% to 70%.

For working environment at a different temperature and humidity, you should contact our Technical Office directly.

To calculate the lifetime we use the following formula:

$$(8) \quad t = \frac{m \cdot f_c}{p \cdot V_{st} \cdot k}$$

m = increase in the axial play between screw and nut in respect of the initial value [mm]
 f_c = correction factor from graph N° 5
 p = contact surface pressure (see page 53 onward) [N/mm^2]
 V_{st} = sliding speed (see page 53 onward) [m/min]
 k = constant of resistance to wear $\left[\frac{\text{mm}^3 \cdot \text{min}}{\text{N} \cdot \text{m} \cdot \text{hrs}} \right]$

Value of the constant k for plastic nuts.

nuts MPH	$k = 10,5 \cdot 10^{-5}$
nuts FCS	$k = 2,5 \cdot 10^{-5}$

Example of lifetime calculation of a plastic nut

Size to wear and calculate the lifetime of the nut FCS operating in the following conditions:

- Constant axial load forces of inertia limited by controlled ramps of acceleration/deceleration of $F = 450 \text{ N}$
- Motion speed = $10 \text{ m}/\text{min}$
- Working time = 12 sec. with downtime = 12 sec.
- Distance covered in 12 sec. at $10 \text{ m}/\text{min} \cong 2000 \text{ mm}$
- Working environment temperature $\cong 22^\circ\text{C}$
- Working environment mean relative humidity $\cong 40\% : 60\%$
- No lubrication
- Minimum lifetime requested: the coupling screw/nut must work for 200.000 cycles (i.e. approx 1.330 hrs at the above conditions) increasing the axial play in respect of the initial value of $0,1 \text{ mm}$.

$V \text{ motion} = 10 \text{ m}/\text{min}$

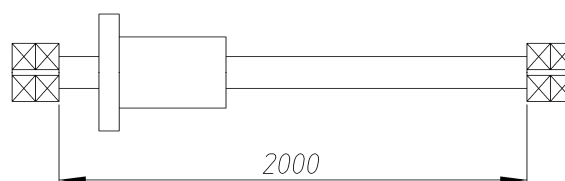

Nuts type FCS are perfectly self-lubricant and therefore suitable to work in the considered conditions. Seen the good motion speed requested (10 m/min) we verify to wear the nut FCS 28 BR, with pitch 10 (2 starts at pitch 5).

To verify the product $p \cdot V_{st}$ see example on page 60.

Contact surface pressure is calculated with (1).

$$p = \frac{F}{A_t} = \frac{450 \text{ [N]}}{3600 \text{ [mm}^2\text{]}} = 0,125 \left[\frac{\text{N}}{\text{mm}^2} \right]$$

The sliding speed is calculated with (4).

$$V_{st} = \frac{V_{tr}}{\sin \alpha} = \frac{10 \left[\frac{\text{m}}{\text{min}} \right]}{\sin 7^\circ 07'} = 80,7 \left[\frac{\text{m}}{\text{min}} \right]$$

The value $p \cdot V_{st}$ is:

$$p \cdot V_{st} = 0,125 \left[\frac{\text{N}}{\text{mm}^2} \right] \cdot 80,7 \left[\frac{\text{m}}{\text{min}} \right] \cong 10 \left[\frac{\text{N}}{\text{mm}^2} \cdot \frac{\text{m}}{\text{min}} \right]$$

Now we calculate the admissible value of the product $p \cdot V_{st}$ at the considered conditions.

From graph N° 3 we see that in continuous working conditions at 23°C with $p = 0,125 \text{ [N/mm}^2\text{]}$ the admissible value of V_{st} is $\cong 180 \text{ [m/min]}$

$$\text{i.e. } (p \cdot V_{st})_{\max} = 0,125 \cdot 180 = 22,5 \left[\frac{\text{N}}{\text{mm}^2} \cdot \frac{\text{m}}{\text{min}} \right]$$

- from chart N° 2 " f_i " = 0,75
- from graph N° 4 " f_t " = 1
- from graph N° 5 " f_c " = 3

- the maximum admissible value of $p \cdot V_{st}$, in this case, with (7) :

$$p \cdot V_{st \text{ amm}} = p \cdot V_{st} \cdot f_i \cdot f_t \cdot f_c = 22,5 \left[\frac{\text{N}}{\text{mm}^2} \cdot \frac{\text{m}}{\text{min}} \right] \cdot 0,75 \cdot 1 \cdot 2 = 33,75 \left[\frac{\text{N}}{\text{mm}^2} \cdot \frac{\text{m}}{\text{min}} \right]$$

As the value of $p \cdot V_{st}$ is here less than the admissible one, the nut FCS 28 BR may be use for this motion.

Verify to wear:

Now we calculate in how long we would face wear in continuous working conditions and therefore an increase of the axial play of 0,2 mm with (8)

$$t = \frac{m \cdot f_c}{p \cdot V_{st} \cdot k} = \frac{0,1 \cdot 2}{10 \cdot 2,5 \cdot 10^{-5}} = 800 \text{ hrs}$$

Therefore 800 working hrs, at the speed of 10 m/min, correspond to the following distance:

$$800 \cdot 60 \cdot 10 = 480.000 \text{ m}$$

$$\text{Number of cycles: } \frac{480.000}{2} = 240.000 \text{ cycles}$$

We have a lifetime of 1.600 hrs. at the considered conditions.

Critical Axial Load (Peak Load)

When there are compression loaded screws allowance must be made for limitations due to peak load to avoid screw bending due to excessive axial compression load. Admissible axial load depends on the core diameter (d_3) of the screw, end constraints (bearings) and free length 'le'.

Regarding the values given in graph no. 6, allow a minimum safety factor ≥ 2 .

Graph no. 6 - Peak Load

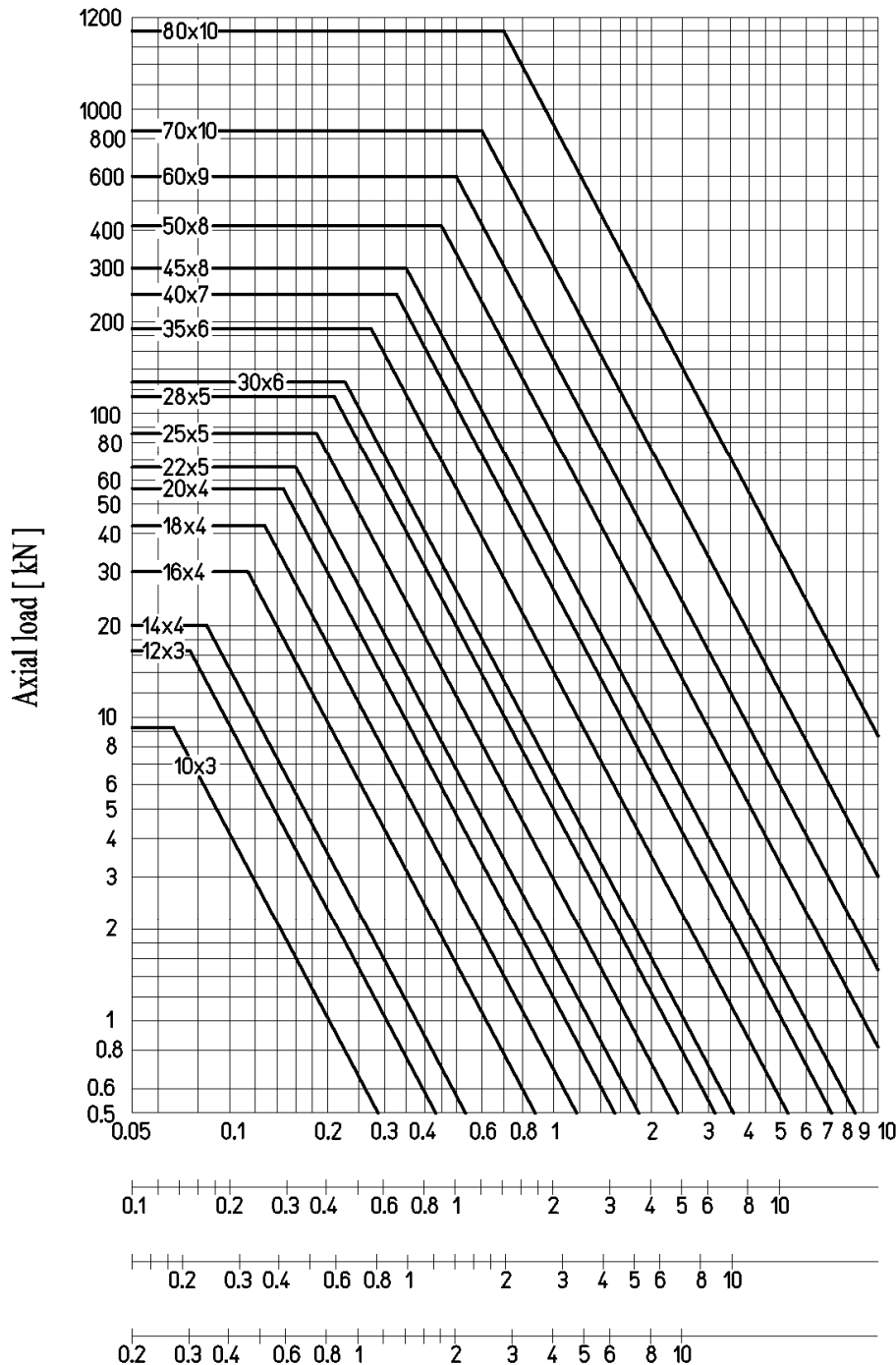

free length "le"
for constraint type

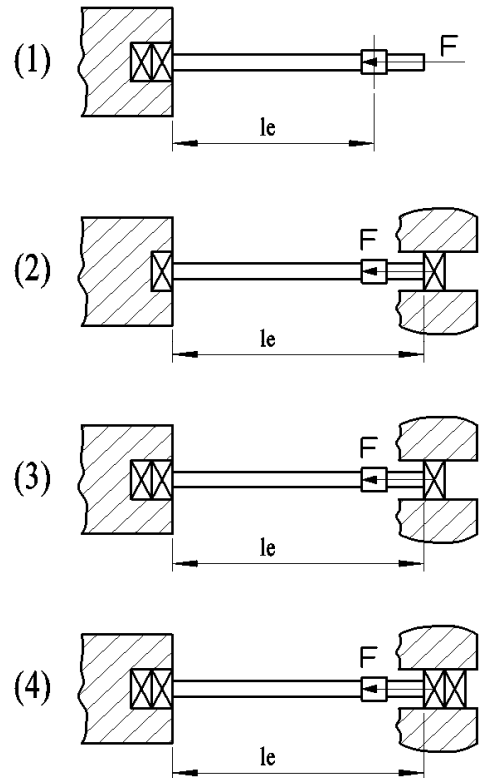

(1) free length "le" [m]

(2)

(3)

(4)

Example: find the admissible axial load of a Tr 30x6 screw 3000 mm long with constraint conditions as in drawing 4.
From graph 6 Take $F_{max} = 11$ kN with safety factor of 2 and assume $F_{adm} = 11/2 = 5.5$ kN.

Critical revolutions per minute

The critical revolutions per minute is the rotating speed at which screw vibrations appear. This rotation speed must never be reached because the vibrations cause serious operating irregularities. Critical rpm depend on screw diameter, end constraints (bearings), free length "lg" and from the assembly accuracy.

For values shown in Graph 7 assume a minimum safety factor related to the assembly accuracy as per the following chart:

Chart n°3 Assembly accuracy coefficient:		
Assembly accuracy	Conditions	Safety coefficient
Good assembly accuracy: - Nut alignment to screw within 0.05mm	Bearing and nut seats obtained from CNC lathe onto an already finished structure.	1.3 – 1.6
Average assembly accuracy: - Nut alignment to screw within 0.10mm	Bearing and nut seats processed on parts which are then assembled together. Alignments are checked by comparators with extreme care after mounting.	1.7 – 2.5
Low assembly accuracy: - Nut alignment to screw within 0.25mm	Bearing and nut seats processed on parts which are then assembled or welded together. Alignments are checked by comparators after mounting.	2.6 – 4.5

Graph no. 7 – Critical rpm

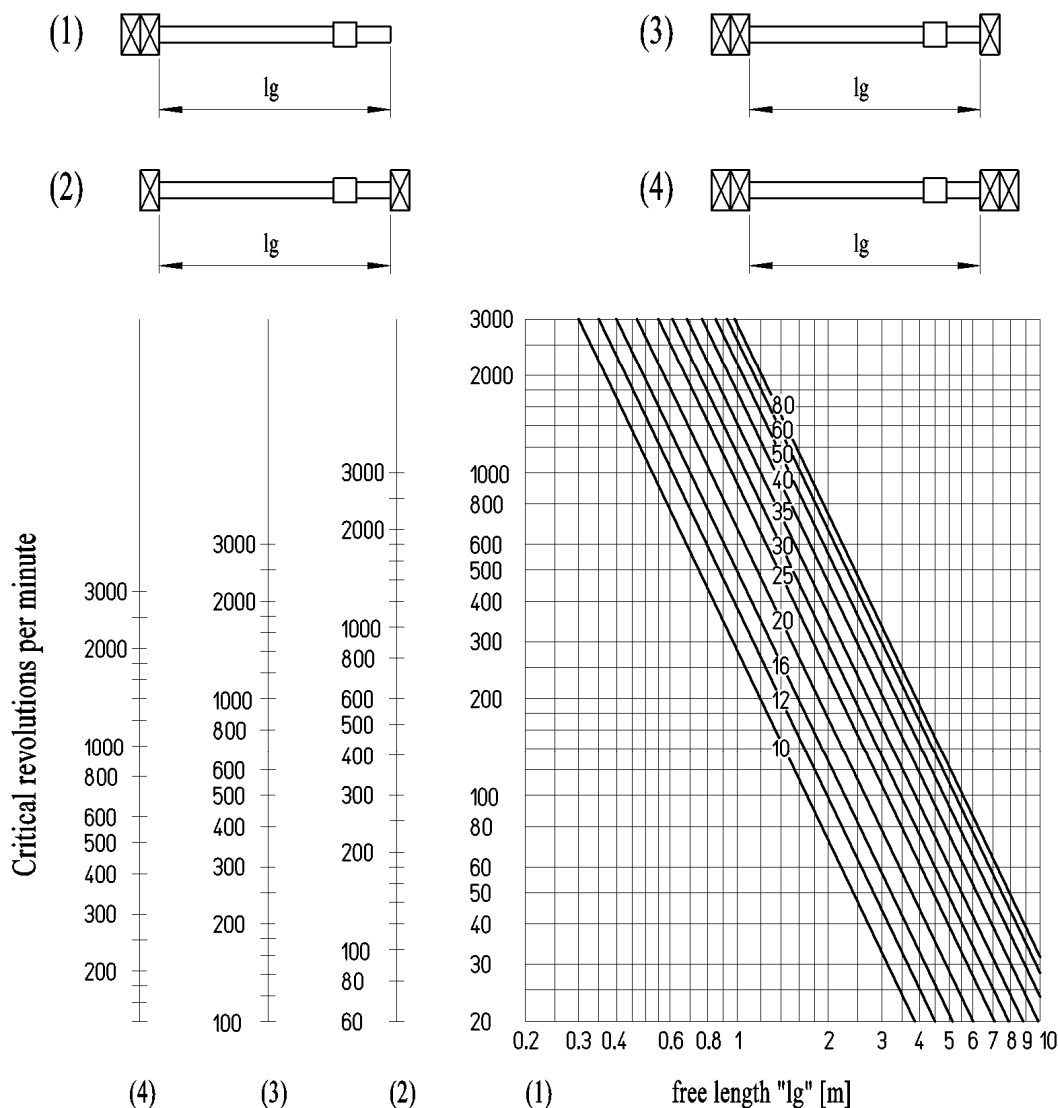

Example: find the critical rpm of a screw Tr 40x7 length 3000 mm with constraint conditions as in drawing 3 with average assembly accuracy. Graph 7 gives critical rotation speed $\cong 1000$ rpm

From chart n°3 we calculate the Safety coefficient = 2.2.

We can reach the working speed at a maximum round speed of: $n. \max = 1000/2.2 = 454$ rpm.

Efficiency

By efficiency is meant the ability of a screw & nut system to convert rotary motion into rectilinear motion. This parameter allows appraisal of how much rotation energy is converted into useful energy for linear movement, hence how much energy is dissipated as heat.

The following formula can be used for calculation.

$$(9) \quad \eta = \frac{1 - f \cdot \operatorname{tg} \alpha}{1 + \frac{f}{\operatorname{tg} \alpha}} \quad \begin{array}{l} \eta = \text{efficiency} \\ f = \text{dynamic friction factor between scrow and nut materials} \\ \alpha = \text{lead angle of threads} \end{array}$$

The numerical efficiency values of each limit are shown in the table ‘Screw Specifications’ on page 52.

Graph no. 8 – Efficiency

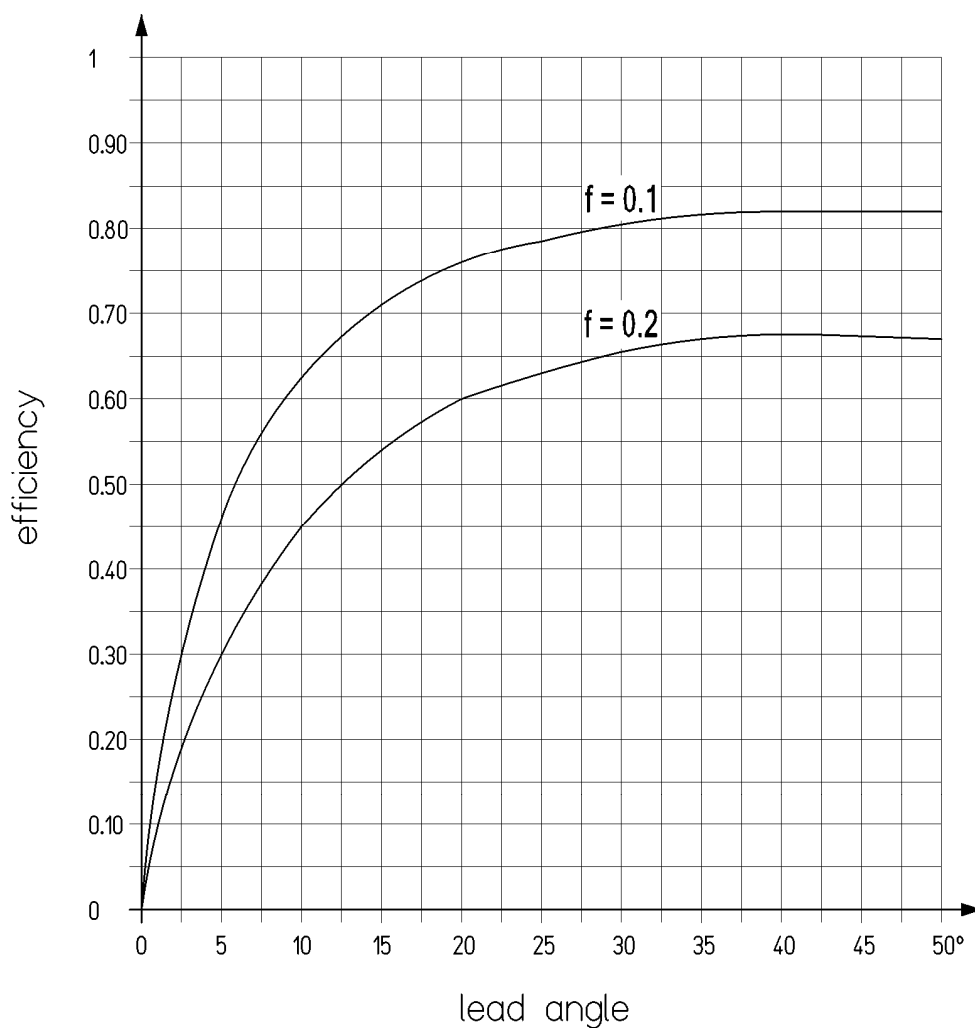

Graph no. 8 shows that efficiency is greater if the lead angle of the screw thread is greater, hence to dissipate less energy as heat, it is recommended to use screws with lead angle as high as possible for the type of work (Pay attention if irreversibility of the system is needed). Efficiency is inversely proportionate to the dynamic friction factor, i.e. using material with a lower friction factor there is less waste of energy. For this reason we make precision rolled trapezoidal screws with minimal roughness on the side of the tooth and always less than 1 μm Ra (usually 0.2 to 0.7 μm). We also make wear-resistant self-lubricating plastic flanged nuts which ensure very low friction factors with no need for lubrication. Dynamic friction factor $f \cong 0.1$, first breakaway $\cong 0.15$.

Torque

The Torque necessary for moving a screw & nut system is calculated by the following equation.

$$(10) \quad C = \frac{F \cdot P}{2 \pi \eta 1000}$$

C = torque (input) [N•m]
 F = axial force on nut [N]
 P = true lead of screw [mm]
 η = efficiency (assume efficiency with first breakaway friction factor $f= 0.2$, Table on page 52)

Example of calculation :

Find torque necessary for movement of a screw Tr 30x6 coupled with a nut HCL Tr 30x6.

Resistant axial force = 10.000 N

Screw lead = 6 mm

$\eta = 0.26$

$$\text{Torque} = \frac{F \cdot P}{2 \cdot \pi \cdot \eta \cdot 1000} = \frac{10.000 \text{ [N]} \cdot 6 \text{ [mm]}}{2 \cdot \pi \cdot 0.26 \cdot 1000} = 36.7 \text{ N} \cdot \text{m}$$

The torque value does not consider the efficiency of mechanical parts moving together with the screw system, such as bearings, belts or other transmission components. In project phase, an increase between the 20 and 30% of the theoretical value is recommended. If electric motors with low static torque are used assume another increase of 50% to find nominal torque.

$$C = 36.7 \text{ [N} \cdot \text{m]} \cdot 1.3 \cdot 1.5 \cong 71.6 \text{ [N} \cdot \text{m]}$$

Power

The power necessary for moving a trapezoidal screw & nut system is calculated with the following equation.

$$(11) \quad P = \frac{C \cdot n}{9550}$$

P = power [kW]
 C = torque [N•m]
 n = rpm

Example of calculation :

Calculate the power necessary for moving the screw Tr 30x6 of the above example at 600 rpm.

$$P = \frac{C \cdot n}{9550} = \frac{71.6 \text{ [N} \cdot \text{m]} \cdot 600 \text{ [round/min]}}{9550} \cong 4.5 \text{ kW}$$

This is the minimum useful power necessary.

Stock number for ordering trapezoidal screws

SCREW	K	Q	X	3	0	A	R	2 3 4 5
	1			2		3	4	5

- 1 - Trapezoidal screw type: KTS -KUE -KKA -KSR -KQX -KEQ -KRP -KRE -KAM -KAF see related pages.
- 2 - Nominal size of screw thread. Numerical value from table.
- 3 - Identifying letter of actual lead and number of threads. See page for screw type and the ordering stock number corresponding to the diameter and lead to order.
- 4 - R = right-hand; L = left-hand.
- 5 - Screw length, specify in millimeters: 2000 = 2.000 mm 2345 = 2.345 mm

Examples of orders:

-- Trapezoidal screw, lead accuracy 200, C15E Tr 50 lead 8 with 1 thread start. RH thread, length 2000 mm entirely threaded:

SCREW	K	Q	X	5	0	A	R	2 0 0 0
	1			2		3	4	5

-- Trapezoidal screw, lead accuracy 200, C15E Tr 40 lead 40 with 5 thread starts. RH thread, length 2500 mm entirely threaded:

SCREW	K	Q	X	4	0	E	R	2 5 0 0
	1			2		3	4	5

Ordering screws with completely finished ends :

Send a drawing by fax or email to our offices. A stock number will be assigned to each individual drawing. For screws completely finished on the ends the straightness value should be specified on the drawing.

PAY ATTENTION TO STRAIGHTNESS WHEN PREPARING ORDERS:

Screws are produced in length of 6 meters but the straightness is checked on a shorter length. The straightness value is specified in the proper column of the features table of each screw type.

To order completely threaded screws:

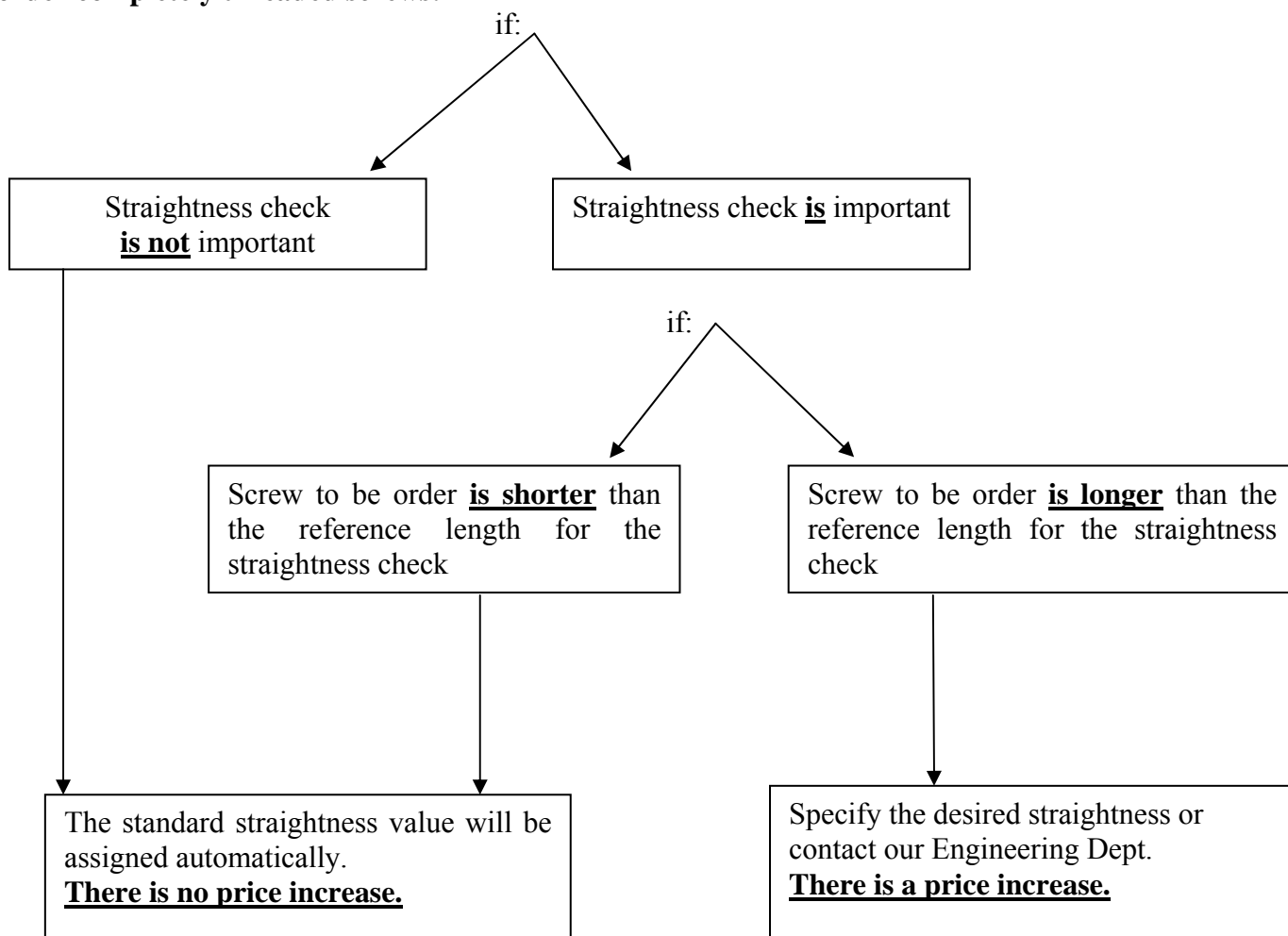

The terms set forth above apply to completely threaded screws.

Ordering screws with fully finished ends:

For screws with fully finished ends the straightness value should always be specified in the drawing.

Stock number for ordering trapezoidal nuts

NUT	F	T	N	2	0	A	R
	1			2		3	4

- 1 - Nut type: MLF - MZP - HSN - HBD - HDA - HBM - BIG - CQA - QOB - CQF - QBF
FTN - FXN - FMT - HDL - CBC - FFR - FHD - CDF - HAL - MES - FCS - MPH see related pages.
- 2 - Nominal size of nut thread. Numerical value from table.
- 3 - Identifying letter of actual lead and number of threads starts. See page for nut type. The letter of the ordering stock number corresponding to the diameter and lead to order.
- 4 - R = right-hand; L = left-hand.

Examples of orders:

-- Flanged trapezoidal nut with length 3xTr bronze GB-Cu Sn12, Tr 40 lead 10 with 1 thread start, RH thread:

NUT	H	D	L	4	0	I	R
	1			2		3	4

-- Cylindrical trapezoidal nut bronze GB-CuSn7ZnPb, Tr 20 lead 4 with 1 thread start, RH thread:

NUT	H	S	N	2	0	A	R
	1			2		3	4

-- Cylindrical trapezoidal nut bronze GB-Cu Sn12, Tr 50 lead 3 with 1 start, LH thread:

NUT	B	I	G	5	0	R	L
	1			2		3	4

-- Cylindrical trapezoidal nut steel 11 S Mn 30, Tr 60 lead 9 with 1 start, RH thread:

NUT	M	Z	P	6	0	A	R
	1			2		3	4

For nuts finished to your drawing:

Send a drawing by fax or email to our offices. A stock number will be assigned to each individual drawing.